

# EIR

Executive Intelligence Review

October 12, 2001 Vol. 28 No. 39 [www.larouchepub.com](http://www.larouchepub.com) \$10.00

LaRouche To Telex TV: Crash Was Already Under Way  
Who Harbors The Terrorist FARC? The 'Grasso Factor'  
When U.S. Officers Planned Terror Attack On America

**Guide For The Perplexed  
To A Changing World Order**



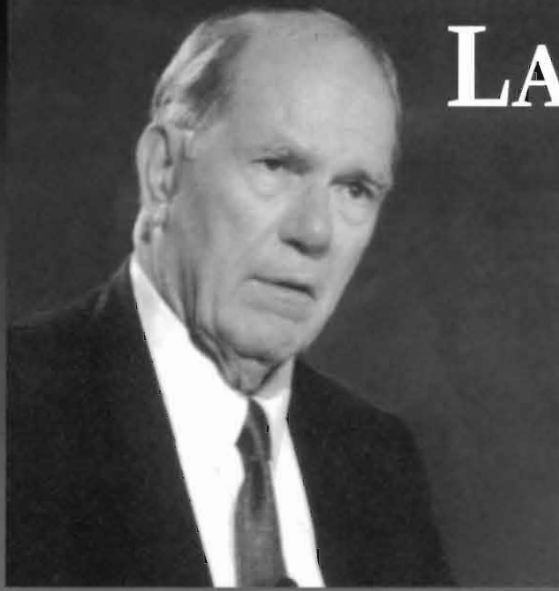

# LA ROUCHE for President

**'You Have Nothing To Fear As Much As Denial Itself'**  
Have courage. Stop looking for retribution against those who have proven guilty of no crime. Face up to what you have lacked the courage to face up to now. Then, together, we shall build this nation out of this horrible nightmare.

—Lyndon H. LaRouche, Jr., Sept. 15, 2001

## SPECIAL REPORT

# How To Defeat Global Strategic Irregular Warfare

A Special Report including reprints from Executive Intelligence Review: Three LaRouche-commissioned 1995 dossiers, detailing the creation and deployment of Osama bin Laden and the 'Afghansi' by U.S., British, and Israeli intelligence services.

208 pages



**\$75** Suggested contribution

### TO ORDER,

Call toll-free:  
**1-800-929-7566**

Write:  
**LaRouche in 2004  
P.O. Box 730  
Leesburg, VA 20178**

On the web:  
**[www.larouchein2004.com](http://www.larouchein2004.com)**

**LA ROUCHE**  
**IN 2004 \***

For more information, call:  
Toll Free 1-800-929-7566  
Washington, D.C. 202-544-7087  
Leesburg, VA 703-777-9451  
Northern Virginia 703-779-2150  
Philadelphia, PA 610-734-7080  
Pittsburgh, PA 412-884-3590  
Baltimore, MD 410-247-4200

Norfolk, VA 757-531-2295  
Houston, TX 713-541-2907  
Chicago, IL 312-335-6100  
Flint, MI 810-232-2449  
Minneapolis, MN 763-591-9329  
Lincoln, NE 402-946-3981  
Mt. Vernon, SD 605-996-7022  
Phoenix AZ 602-992-3276

Los Angeles, CA 323-259-1860  
San Leandro, CA 510-352-3970  
Seattle, WA 206-362-9091  
Ridgefield Park, NJ 201-641-8858  
Boston, MA 781-380-4000  
Buffalo, NY 716-873-0651  
Montreal, Canada 514-855-1699

Founder and Contributing Editor:

*Lyndon H. LaRouche, Jr.*

Editorial Board: *Lyndon H. LaRouche, Jr.,  
Muriel Mirak-Weissbach, Antony Papert, Gerald  
Rose, Dennis Small, Edward Spannaus, Nancy  
Spannaus, Jeffrey Steinberg, William Wertz*  
Editor: *Paul Gallagher*

Associate Editors: *Ronald Kokinda, Susan Welsh*

Managing Editor: *John Sigerson*

Science Editor: *Marjorie Mazel Hecht*

Special Projects: *Mark Burdman*

Book Editor: *Katherine Notley*

Photo Editor: *Stuart Lewis*

Circulation Manager: *Stanley Ezrol*

INTELLIGENCE DIRECTORS:

Asia and Africa: *Linda de Hoyos*

Counterintelligence: *Jeffrey Steinberg,*

*Michele Steinberg*

Economics: *Marcia Merry Baker,*

*William Engdahl*

History: *Anton Chaitkin*

Ibero-America: *Dennis Small*

Law: *Edward Spannaus*

Russia and Eastern Europe:

*Rachel Douglas*

United States: *Debra Freeman, Suzanne Rose*

INTERNATIONAL BUREAUS:

Bogotá: *Javier Almaro*

Berlin: *Rainer Apel*

Buenos Aires: *Gerardo Terán*

Caracas: *David Ramonet*

Copenhagen: *Poul Rasmussen*

Houston: *Harley Schlanger*

Lima: *Sara Madueño*

Melbourne: *Robert Barwick*

Mexico City: *Marivilia Carrasco, Rubén Cota*

*Meza*

Milan: *Leonardo Servadio*

New Delhi: *Susan Maitra*

Paris: *Christine Bierre*

Rio de Janeiro: *Silvia Palacios*

Stockholm: *Michael Ericson*

United Nations, N.Y.C.: *Leni Rubinstein*

Washington, D.C.: *William Jones*

Wiesbaden: *Göran Haglund*

*EIR (ISSN 0273-6314) is published weekly (50 issues) except for the second week of July and the last week of December, by EIR News Service Inc., 317 Pennsylvania Ave., S.E., 3rd Floor, Washington, DC 20003. (202) 544-7010. For subscriptions: (703) 777-9451, or toll-free, 888-EIR-3258.*

*World Wide Web site: <http://www.larouchepub.com>  
e-mail: [eirns@larouchepub.com](mailto:eirns@larouchepub.com)*

**European Headquarters:** Executive Intelligence Review Nachrichtenagentur GmbH, Postfach 2308, D-65013 Wiesbaden, Bahnstrasse 9-A, D-65205, Wiesbaden, Federal Republic of Germany  
Tel: 49-611-73650. Homepage: <http://www.eirna.com>  
E-mail: [eirna@eirna.com](mailto:eirna@eirna.com) Executive Directors: Anno Hellenbroich, Michael Liebig

**In Denmark:** EIR, Post Box 2613, 2100 Copenhagen ØE, Tel. 35-43 60 40

**In Mexico:** EIR, Serapio Rendón No. 70 Int. 28, Col. San Rafael, Del. Cuauhtémoc, México, DF 06470. Tels: 55-66-0963, 55-46-2597, 55-46-0931, 55-46-0933 y 55-46-2400.

**Japan subscription sales:** O.T.O. Research Corporation, Takeuchi Bldg., 1-34-12 Takatanobaba, Shinjuku-Ku, Tokyo 160. Tel: (03) 3208-7821.

Copyright © 2001 EIR News Service. All rights reserved. Reproduction in whole or in part without permission strictly prohibited. Periodicals postage paid at Washington D.C., and at an additional mailing offices.  
Domestic subscriptions: 3 months—\$125, 6 months—\$225, 1 year—\$396, Single issue—\$10

**Postmaster:** Send all address changes to *EIR*, P.O. Box 17390, Washington, D.C. 20041-0390.

## From the Associate Editor

**T**his morning, I woke up to the sound of the CNN news broadcaster cheerfully babbling that some government agency had ascertained that U.S. unemployment had “held steady” over the month of September.

How’s that again?

The lying propaganda campaign of the U.S. media has truly reached new lows in its immorality, both in the “coverage” of the economic crisis now hard upon us, and in the black propaganda about Osama bin Laden. While many Americans suspect that they are being lied to, they find themselves all the more confused, and frightened. Such is the brainwashers’ intention.

Lyndon LaRouche’s “new guide for the perplexed,” which we feature in this issue, addresses that confusion from the highest conceptual plane, pointing the way for citizens to become “unconfused.” “The way in which a mass-delusion is being willfully fostered by a lying mass-media,” he begins, “must be understood scientifically from the standpoint outlined below.” He proceeds to unfold for the reader a rich tapestry of history, science, and philosophy, to the end that he or she might come to understand the method by which LaRouche himself has become the world’s best economic forecaster. Read this article slowly, and re-read it. Your mastery of the truths contained herein, may very well determine whether you, your family, and your nation survive the turbulent months immediately ahead.

Elsewhere in this issue, we address the real issues of the “post-Sept. 11 world.” In an interview with a television station from Sonora, Mexico, LaRouche gives an overview of the current strategic and economic situation (see *Economics*). Once again, he insists that the heart of the problem lies chiefly inside the United States, with a *domestic* rogue operation that deployed terrorism against the nation. In *International*, we document how official Wall Street has already, openly, given its support to terrorism in Colombia, with its embrace of the FARC drug traffickers. And in *National*, we report the chilling story of how, during the 1960s, a clique in the U.S. Joint Chiefs of Staff proposed covert terrorist attacks against U.S. nationals, in order to galvanize public support for an assault on Cuba. Thankfully, President Kennedy declined to take their advice.

*Susan Welsh*

# EIR Contents

## Cover This Week

*“The Parable of the Blind Men,” by Pieter Breugel the Elder.*



### **12 A New Guide For The Perplexed: How The Clone Prince Went Mad!**

By Lyndon H. LaRouche, Jr. Originally composed on the day before the terrifying events of Sept. 11, this document was amended afterward by the author. It is a technical manual, a guide for the perplexed, supplied to assist counterintelligence specialists and relevant others in overcoming the perplexities of the presently onrushing, profound changes in the world's order.

## Economics

### **4 LaRouche On ‘Telemax’ TV: Crash Was Already Under Way**

Interviewed by a TV and radio station from Hermosillo, Sonora, Mexico, Lyndon H. LaRouche, Jr. evaluated the world economic and strategic situation, in the aftermath of the Sept. 11 terror attacks, and outlined the policy that must be adopted now.

### **6 Congress Eyes A Real Stimulus: High-Speed Rail**

The so-called financial stimulus package being debated in Washington, won't resuscitate a bankrupt economy. What's needed is great projects to reconstruct and expand the decrepit infrastructure of the physical economy, as some congressmen are beginning to notice.

### **8 Russia Stands Out At World Rail Conference**

The World Railway Congress met in Vienna, representing 70 countries, with speakers from rail ministries and national rail enterprises, the World Bank, the European Union, and the private sector.

### **11 Pakistan Gets A Little Financial Relief . . . But Nothing More**

## International

### **58 Who Harbors Terrorist FARC Cartel? The ‘Grasso Factor’**

Wall Street’s support for the narco-terrorist insurgency in Colombia, gives the lie to U.S. ‘global war on terrorism.’

### **60 U.S. Still For Talking To Colombian Terrorists**

### **63 Putin: Attack Drug And Terror Infrastructure**

## National

### **64 When U.S. Joint Chiefs Planned Terror Attacks On America**

Top levels of the U.S. military proposed carrying out acts of terrorism against the United States in the early 1960s, in order to drag the United States into a war against Cuba. Documents which were supposed to have been destroyed 40 years ago, take on added significance, in light of the Sept. 11 terror attacks.

### **66 Temple Mount Madmen Go For Armageddon**

### **67 Some Background To Pat Robertson’s Crusade**

An interview with former U.S. Rep. Andy Jacobs, Jr.

### **69 National News**

### **70 Congressional Closeup**

## Interviews

### **67 Andy Jacobs, Jr.**

The former U.S. Representative talks about Pat Robertson’s flopped libel suit against him and California Republican Pete McCloskey.

## Departments

### **72 Editorial**

It’s What They Haven’t Told You.

### **Photo and graphics credits:**

Cover, pages 16, 18 (Ptolemy, Copernicus), www.arttoday.com. Page 6, Transrapid website. Page 9, European Union. Page 10, Russian Ministry of Transport. Page 11, UN Photo. Pages 21, 46 (Vernadsky), EIRNS. Pages 23, 65 (collage) EIRNS/Stuart Lewis. Page 24, Library of Congress. Page 31 (St. Mark’s), EIRNS/Guggenbuhl Archive. Page 36 (statue), EIRNS/Bonnie James. Page 41, Feature Photo Service. Pages 46 (Mars), 53, NASA. Page 49, EIRNS/George Hollis. Page 57, TVA. Page 58, ANCOL/Fernando Ruiz. Page 59, ANCOL/Miguel Angel Solano. Page 65, NATO. Page 68, EIRNS/Roger Ham.

## LaRouche On ‘Telemax’ TV: Crash Was Already Under Way

*Lyndon LaRouche was interviewed on Oct. 2, 2001 by Sergio Romano, the host of the “Editor’s Desk” news show on Telemax TV and radio, in Hermosillo, Sonora, Mexico. The show is seen and heard throughout the northwest of Mexico, and into parts of the U.S. Southwest.*

**Telemax:** Greetings, Mr. LaRouche.

**LaRouche:** Thank you.

**Telemax:** Mr. LaRouche, about 20 years ago, you forecast an economic crisis, of the sort we’re experiencing today. How did you know that this was going to happen, and what are the measures that can be taken to solve this crisis?

**LaRouche:** Well, this was foreseeable, if you looked at the axiomatic features, which are like the axioms of a geometry: The changes that were made between the middle of the 1960s and the August 1971 decision of Richard Nixon. And, then you had—at the end of the 1970s—you had the actions of the Carter Administration, which were a greater disaster for the United States, than even the Nixon Administration. And those mistakes were never corrected. Therefore, the crash was inevitable. There could have been certain things done to prevent it—

**Telemax:** Forgive me for interrupting you, Mr. LaRouche, but, are you saying that the end of the Bretton Woods system and the decision to establish floating exchange rates, that these were part of the problem?

**LaRouche:** This was the key to it.



**Telemax:** So, in other words, this was inevitable, because we shifted from a world of production to a world of speculation. Is that the case?

**LaRouche:** That’s essentially it.

**Telemax:** So, in other words, we’re giving benefits to those who speculate and not those who produce. What can be done to change and correct the situation?

**LaRouche:** Well, now, we’re in what is, for many people, an impossible situation. We have, actually, the worst financial crisis and monetary crisis in world history; it is now unfolding. There are solutions, but there are no simple solutions.

What we have to do, is, essentially, put the world into bankruptcy reorganization. Of course, you’re dealing with national economies, not individual, major firms, so, therefore, it’s different politically than another kind of bankruptcy. And, therefore, what we have now, is not just a financial crisis; we now have a world *political* crisis, not because the world is unwilling to face the crisis, but because the present political institutions are unwilling to face the *reality* of what has to be done.

Naturally, since I knew this was happening, I’ve had, for years, I’ve had exact statements of policy on what has to be done—for which, as you may know, I was not thanked. The question is now: Is the world going to face reality, and be willing to take the kinds of measures which I’ve indicated ought to be done? Otherwise, we’re looking at something like the fall of the Roman Empire.

**Telemax:** Regarding the attack on Washington and New York on Sept. 11, how does this affect the situation? Does this change it? What does it do? Or does it simply precipitate what was coming anyway?

**LaRouche:** No. It doesn’t really affect the economy that much, because the catastrophe is already that great. What this



is, is, actually, a coup d'état inside the United States. And, the question is: Is the United States going to be able to resist this coup d'état, which, if it does, that means we're back to the question of dealing with the financial crisis, not this war-like situation. But the economic crisis has nothing to do with this particular attack on New York and Washington.

**Telemax:** You're using the phrase, "a *coup d'état* inside the United States." Are you saying that there's an internal factor involved in this, different from the Arab groups that have been noted in the press?

**LaRouche:** The Arabs, as groups, had really nothing to do with this, except some members may have been involved. You have a lot of attempts to try to distract attention from the fact, but, the fact is: The heart of the problem lies chiefly inside the United States. It's simply impossible to do what was done, except by a very high-level operation from inside the United States.

And, obviously, this has to do with two things. It has to do with the reaction to the world financial crisis. Remember, the coup that put Hitler in power in Germany, came in such a crisis. This has some of the same characteristics as that. And, at the same time, this is tied to the Middle East crisis.

For example: Right now, this weekend, there's the threat of an attack on the famous mosque on the top of the mountain in Jerusalem, the place which is called in Arabic, "al-Haram al-Sharif," which is the second or third holiest place in Islam. You have Protestant forces, in the United States, who believe in having the Battle of Armageddon now. They're crazy, but, unfortunately, they're numerous. They're planning, this weekend, if possible — if they're allowed to — to continue the attacks which correspond to what Sharon did in the first attack on the mountain, some months ago.

What's dangerous, is, if this were to go forward, this would ignite an international religious war, which some people in the United States want: They call it, a "Clash of Civilizations."

So, that's the problem.

**Telemax:** Would you link what happened in New York and Washington, D.C., in any way, to what happened in Oklahoma City at the Federal Building?

**LaRouche:** Well, I would say that, anyone who thinks, in the United States, with regret — that this guy, Nichols and his friend, were ever charged without a thorough investigation in the Oklahoma case. The fact that this was never adequately investigated, but that they simply took the nearest person to charge, and took him out and hung him, so to speak, closed the door on investigations which should have been made. But, undoubtedly, the way this was handled — the mishandling of the Oklahoma bombing case, from an investigation standpoint — does raise questions, because there are people inside the United States who might be used for the kind of thing that happened. From a standpoint of political motivation, these

types of people that were involved behind the Oklahoma bombing, are precisely the kinds of people who would be useful, shall we say, for this kind of attack.

**Telemax:** Mr. LaRouche, you spoke recently at the Russian Duma. You've also undoubtedly seen the statements of President Vladimir Putin before the German Bundestag, and you've discussed the issue of a realignment politically, of Europe toward Eurasia. Is that the direction that you see things moving?

**LaRouche:** I see the direction they *should* move in. If we're going to get out of an economic crisis, we have to revive world trade, and the major market for that, essentially, lies in Asia: China, India, so forth. Now, therefore, we have to create the mechanisms of cooperation for long-term trade. If we do that, we could, quite successfully, revive the world economy.

There exist plans, which I've been involved in devising, which are now accepted in various parts of that part of the world, including a project called the "Eurasian Land-Bridge" project, which would involve all of continental Eurasia, or nearly all of it, from the Atlantic to the Pacific. It also involves putting a railroad tunnel into Alaska from Siberia, and the plan is to continue that road all the way down to Tierra del Fuego. There are also plans in Egypt, to extend the same system into Africa. This project could result in the greatest economic revival the planet has ever known.

My view is that, if we could get such a plan into motion, with the cooperation of the United States, that we can solve all the major problems which now confront us. We need a project to put the world back together.

**Telemax:** Mr. LaRouche, you're running for President in the year 2004. How's your campaign going? What are your activities? And what alternatives are you presenting to the U.S. population for the year 2004?

**LaRouche:** Essentially this one: first of all, to get the cooperation with the Land-Bridge. To launch a large-scale credit operation inside the United States, for the expansion of production based on the new markets. And also, to eliminate many of the changes in policy which were made by Nixon, Carter, and so forth, and go back to the things that worked before.

Which would mean that U.S. relations with Mexico, for example, would go back to what they were, say, in the late 1970s, at which time there were many plans for cooperation between the United States and other countries. If we get back to the spirit of those discussions, I think we'll be in good shape.

**Telemax:** Mr. LaRouche, thank you so much, for taking my call. It's been a pleasure interviewing you, and I wish you the best of success in your activities.

**LaRouche:** Thank you, very much.

# Congress Eyes A Real Stimulus: High-Speed Rail

by Marcia Merry Baker

The first week of October was economic “stimulus package” week in Washington; the administration and Congressional leadership held repeated meetings, and made announcements committing to an overall dollar amount of some \$75 billion—not counting \$40 billion for national security and to help New York City, and \$15 billion in aid to the airlines. The content of the package (whether tax cuts, unemployment benefits and health care measures, capital gains breaks for market speculators, etc.) remained unformulated and highly contested on Capitol Hill, but on Oct. 3, President George Bush went to New York City, to announce commitment to speedy action.

In fact, the formulations under consideration so far, do not constitute stimulus. Given how fast the U.S. economy is collapsing, what’s required would better be called economic “resuscitation.” But still the talk persists of “confidence building” as if that’s all that’s necessary. Americans are urged to simply: shop, travel, and buy! On Oct. 2, Glenn Hubbard, Chairman of the Council of Economic Advisers, spoke in such terms of unreality, when he testified to the Senate Budget Committee.

Lyndon LaRouche has described this kind of denial by policy makers, as worse than the economic crisis itself.



*Magnetically levitated trains fill the bill, in every respect, for the new high-speed North American rail corridors, which are finally breaking into the open in Congressional debate. Here, the Transrapid maglev is tested in Germany, which is constructing such lines for China.*

(See p. 4).

As *EIR* has documented, the U.S. and global financial system and economy were far along in the process of breakdown, well before the Sept. 11 attacks. Globally, there are some \$400 trillion of financial obligations, contrasted to some \$40 trillion of total gross domestic product. Whole nations, such as Argentina or Turkey, are in turmoil over the lack of intervention to set aside the debt and keep their national economies going.

In the United States, the total debt load (all kinds) is huge and unpayable—from airlines, to households, to states, to steel, railroads, and throughout all vital sectors. At the same time, economic activity is shrinking rapidly: 200,000 layoffs in a three-week period, bankruptcies, shutdowns. This is a collapse dynamic: chain reactions of insolvencies and chaos. Sticking with patriotic appeals to confidence, is a con game that won’t work.

## Lack Of Rail Infrastructure Decried

One place where the gravity of the situation has begun to be acknowledged is Congress’s recognition of the miserable state of U.S. infrastructure—particularly railroads. It may be “Johnny Come Lately,” but reality has struck. On Oct. 2, over five hours of discussion took place on Capitol Hill, at two hearings: first, at the Senate hearing on Railroad and Maritime Security, in the Transportation Subcommittee, chaired by Sen. John Breaux (D-La.); and second, in the House of Representatives, at the hearing in the Committee on Transportation and Infrastructure, convened on the topic of the newly introduced, largely Republican bill, “Rail Infrastructure Development and Expansion Act of the 21st Century” (RIDE-21).

Congressmen from both parties and around the nation, gave details from their regions, of choke-points and bottlenecks from the lack of railroad capacity and water navigation infrastructure. They reported chain-reactions of transportation congestion from the Sept. 11 attacks, because of the lack of contingency transport infrastructure. Sen. John Kerry (D-Mass.) told of *Tanker Matthews*, carrying liquefied natural gas (LNG) from Algeria to Massachusetts, being diverted to Savannah, Georgia right after the attacks, because the port in Everett, Mass. cannot be made secure. There are only six secure ports in the nation. Kerry added that New England is 20% dependent on LNG, and no shipments have been made for nearly a month, due to lack of in-port security.

At the House Committee hearing, there were over three hours of accounts, detailing the inadequacy of the rail system, and need for improvement projects. One example: There used to be six parallel corridors of



FIGURE 1□

## U.S. Railroad Mileage Decline, 1950-1997□

(miles per 1,000 households)

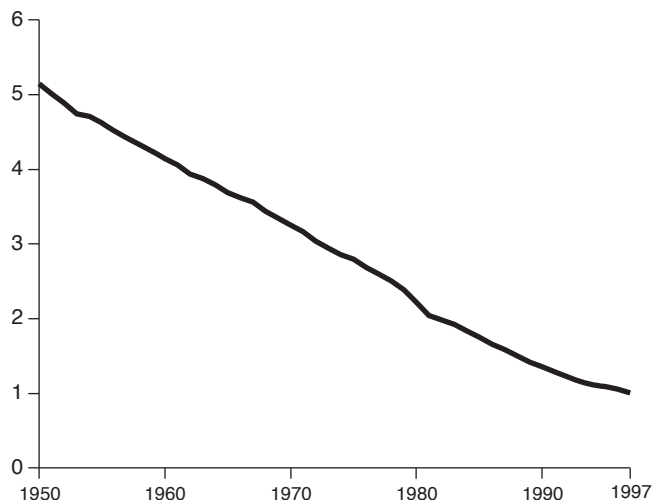

Sources: Association of American Railroads; U.S. Department of Commerce, Bureau of the Census, *Population Surveys*, various years.

rail connecting the Northeast to the Midwest. Now there are only three, and two of them use one critical rail bridge in Ohio! **Figure 1**, shows the steep decline in railroad track mileage (shown as miles per 1,000 households) in the United States over the last 50 years. The state of Iowa, for example—a major agricultural producer for both national and international consumption—saw the loss of one-third of its rail grid in only the 1980s!

The RIDE-21 rail expansion bill, was introduced on Sept. 25 by Rep. Don Young (R-Ak.), as H.R. 2950. It calls for some \$71 billion of different types of funding, from tax-exempt bonds, to loan guarantees, to grants for rail corridor planning. An earlier bill, largely sponsored by Democrats, is H.R. 2329, the “High Speed Rail Investment Act of 2001.” Both are intended to rebuild sections of the U.S. rail grid, and to build high-speed rail networks, including, potentially, magnetically-levitated train systems. Many Congressmen have travelled to Germany for a test ride on the Transrapid prototype, shown in the photo.

Twelve priority links for high-speed systems are implied or indicated in the proposed bills:

**West:** Corridors in California and the Northwest (including Vancouver, Canada)

**Texas and South:** Texas to Arkansas, and through Louisiana, on to Mobile, Alabama, and Atlanta

**Midwest:** Kansas up to Minnesota, and eastward to Michigan and Ohio

**Southeast:** Florida northward

**Northeast:** To Great Lakes, Eastern Seaboard

**Alaska Corridor:** Through Canada to the “Lower 48.”

These two rail bills under consideration—and there are others—are part of the momentum forming for infrastructure building as the policy response to restore the economy. The H.R. 2329 “High-Speed Rail” Bill specifies only \$12 billion, in contrast to the \$71 billion of RIDE-21. A Congressional staff member commented, “We proposed \$12 billion before the Sept. 11 incidents. If we had proposed \$70 to \$80 billion then, we would have been denounced as crazy, and the legislation wouldn’t have been considered. But since Sept. 11, things are changing.” The sum of \$12 billion is far too low, of course, as is \$71 billion. A sum of \$100 billion is more in the range of what’s practical to upgrade the existing rail system. This is the estimate of transportation consultant Hal Cooper, who figures on rebuilding up to 70,000 track-miles of lines up to double- and triple-track specification.

But at present, it is the momentum and policy direction that count. On Sept. 8, LaRouche advised, “The crash is on! It’s time for all good Democrats to propose public works, public spending on economic infrastructure.”

## Senator Reid: Domestic Marshall Plan

A leader of the infrastructure drive in Congress is Sen. Harry Reid (D-Nev.), the number-two man in the Senate. For some time, he has backed a plan for at least \$37 billion for rail improvements, but he is outspoken for the need to act on upgrading the entire national infrastructure base across the board—from water treatment and sewers, to hospitals, rail, and more.

He called for a “Marshall Plan for Renewal” in a speech on Aug. 18 at the Tahoe Forum Speakers Series, at Sierra Nevada College in Nevada. He said, “As vastly different as our favorite places may seem, they are all connected. They are tied together by the thousands and thousands of public works projects which make up America’s web of physical infrastructure.

“Our infrastructure is more than just the network of roads, bridges, railways, seaports, and airports which take us to our favorite places. It’s also the systems which bring us clean drinking water and treat our wastewater. It’s the power grids, which light our homes and the school buildings where we hope our children become enlightened.

“America’s public works projects are not only the physical backbone of this country. . . . They are the muscle system which provide goods jobs—to both skilled and unskilled labor.”

The “multiplier effects” from the rail expansion program would be gigantic—for example, the material requirements for steel, concrete and other inputs. Consider the fact that, for a new “Al-Can” rail corridor, going from Alaska, through Canada to the Lower 48, the need would be for 1,300 new track-miles in the trunk route. At a factor of 2,500 tons of steel for a double track (including for culverts, bridges, etc.), this means a need for 3.25 million tons of steel for this corridor alone.

# Russia Stands Out At World Rail Conference

by Mary Burdman

Simultaneous with Russian President Vladimir Putin's notable visit to Germany, a high-level Russian Ministry of Railway Transport delegation stood out at the World Railway Congress in Vienna on Sept. 25-28. In the U.S. Congress, Federal rail corridor development plans were emerging for the first time in decades. At Vienna, some 500 participants from 70 countries in Europe, Asia, Africa, and North and South America, discussed the present and future of rail transport. Speakers came from rail ministries and national rail enterprises, the World Bank, the European Union (EU), and the private sector.

With some interesting exceptions, speakers from the United States and West and Central Europe, retained their commitment to the liberal market, even while being forced to admit, over and over, how big a toll the last 25 years' market "reforms" have taken, devastating every aspect of rail transport. Most repeated that rail systems can only be revitalized by bowing to the rule of the market, and sharpening rail's "competitiveness" with other modes of transport—although it was universally agreed that rail transport is far more efficient and beneficial, economically and environmentally, than road transport. This approached the level of parody, when a manager of the East Japan Railway Company stressed that "customer satisfaction"—not with a train ride, but with shopping malls in the train stations—was the key to revitalizing Japan's rail system.

More brutally, the nations of South America were also cited as key examples of the use of the liberal market. Argentina's rail lines are now being made more "successful" with mass layoffs. Overall on the continent—one of the least-developed in the world—what short stretches of rail line even exist, have all been sold to "the market." In 1990, all South American railroads, few as they were, were under state operation; in just one decade, all had been privatized. Huge "savings" were generated—through mass layoffs.

## Strategic Perspective

The Russian speakers, including Vyacheslav Petrenko, Deputy General Director of the Russian Ministry of Rail Transport, and First Deputy Minister of Railway Transport Alexander Misharin, however, took a more strategic perspective. They emphasized the growing importance of land transport between Europe and Asia, and Russia's role as the key transport link for Eurasian traffic.

In Western Europe, such a strategic perspective has fallen

victim to the stampede into the International Monetary Fund's "Washington Consensus" financial-economic policy of the past decade. Klaus Eberling, director of European affairs for Deutsche Bahn International, noted in his speech that in the 1960s and beginning of the 1970s, European railroad policy-makers had been discussing the possibility to create a unified rail system. It would have become the longest and likely most utilized rail system in the world, overtaking those of Russia, India, and China.

"How much the world has changed," remarked Eberling. By 1985, the European Commission was laying out how to base transport policy on the "liberal market," and modelling itself on America's deregulation policy. Eberling is apparently unaware that the crash of the U.S. economy is worst in these deregulated sectors.

Europe, East and West, had its great opportunity of the 20th Century in 1989-90, when the continent was reunited. In the years that followed, European leaders did propose developing the Pan European Transport Network, which included greatly expanding high-speed rail lines in Western Europe, and creating, through construction and technical improvements, the "Transport Corridors I-X" which were worked out in serious detail at conferences in Crete in 1994, and Helsinki in 1997. However, to date, just one-fifth of these projects have been achieved. In addition, EU "reform" policy, has been to separate rail infrastructure from operation, although it was acknowledged that this approach undermines the capability for international cooperation.

## The End Of The Market?

Warnings, although muted, did emerge of the consequences of the reign of liberalism in so vital a sector as transport. Wilhelm Haberzettl, head of the Austrian Rail Workers Unions, stated that the deregulation of the European railroads, including the "social dumping" of labor and the lack of investment, is jeopardizing safety along the railroads. Such effects will be especially bad in the nations trying to join the EU, such as Poland. The EU must face, that it has to deal with the social consequences of further liberalization, he said.

EU official John Rees also had to acknowledge the utter lack of success of liberalization. He described the falling level of national investment in transport, a process which coincided with the very sharp rises in road use, for freight and passengers, which has led to serious congestion, environmental problems, and security problems, including the extreme dependence upon imported oil. European transport is 98% dependent upon oil, and 70% of it is imported.

Things were different in the 1960s, he noted, when German Transport Minister Georg Leber wanted to introduce legislation to force goods back onto the railroads, to the benefit of the entire economy. Such is not current thinking, but it may have to change, Rees noted. If the current attempts to "revitalize alternatives to roads," and "target investment" into rail lines do not work, and the already-barely-tenable congestion of Europe's cities, highways, and air transport worsens,

FIGURE 1

## 1994: European Union Projects

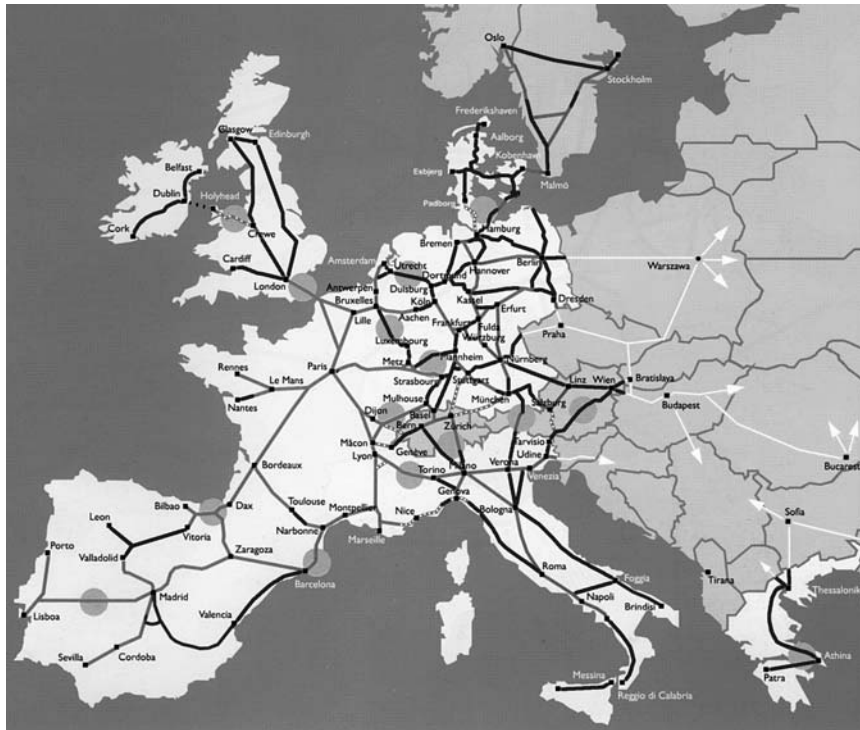

*These high-speed rail corridor projects were formally agreed on by the European Union in 1994—but only one-fifth of the plans have been carried out even in West Europe, as the failed U.S.-British “free market” philosophy for rail transport took hold.*

the whole “market approach” to transport will be under question, he said. If transport cannot solve its own problems, national ministers will come in and announce, “I am going to regulate.”

One rather brutal irony, as several speakers pointed out, is that the long-term aim of the European railways, to become the most efficient, fastest—and most secure—mode of transport in any circle up to 700 km in diameter, has yet to be realized. Now, the attacks in the United States on Sept. 11, using airplanes, have made it all the more urgent to build a secure high-speed network, which can relieve the congestion and pressure on the airlines for short- and medium-length travel.

### ‘Longest Land-Bridge In The World’

In Eurasian traffic as well, there have been serious upheavals in the last decade. The move to market economy has been one of the greatest, especially the lack of financial resources for the railroads. But rail transport is essential. In Kazakstan, rail traffic is 90% of the transport system; in other nations in Central and East Asia, rail transport is vital due to long distances and the primitive state of the roadways.

In his speech on Sept. 26, Vyacheslav Petrenko stated that Russia must adapt its policy to the increasing transport volume between Europe and Asia. The Russian railroad, he said, which has links with nations all over the world, can become the major link between Europe and Asia. Russia not

only wants to expand the transport on the “Euro-Asian rail route,” Petrenko said, but also is developing the “North-South corridor” which links the Trans-Siberian main line with Iran and the Indian Subcontinent. The Trans-Siberian Railway also links to the Pan European Transport Corridors proposed by the European Union in 1994. The 15,000 km Trans-Siberian is “the longest land-bridge in the world.”

While Euro-Asian transit rail traffic remains less than 10% of the total volume on Russia’s rail lines, much is being done to change this, especially on the Trans-Siberian main line. The largest portion of freight volume there is still exports of Russian oil, coal, and chemicals. But measures are being taken—including new customs codes, greatly improved tracking by means of satellite positioning—aimed at increasing Euro-Asian transit traffic. The Trans-Siberian now transports at an average speed of 1,000 km per day, but this must be increased.

Container corridors are critical, and Russia is developing new container technology. It is investing in its own St. Petersburg-Moscow rail corridor to make it possible to use the most advanced container technology on this stretch.

The Trans-Siberian “transport corridor” is being extended directly into the Korean Peninsula and Central Europe, Petrenko said. Immediately, Russia is emphasizing cooperation with North Korea and China on the Asian end of the Trans-Siberian, and with Hungary, Ukraine, Belarus, and the Czech Republic on the European end. Russia wants to extend build-

FIGURE 2

**2001: Russian Ministry of Transportation's 'Main Directions'**

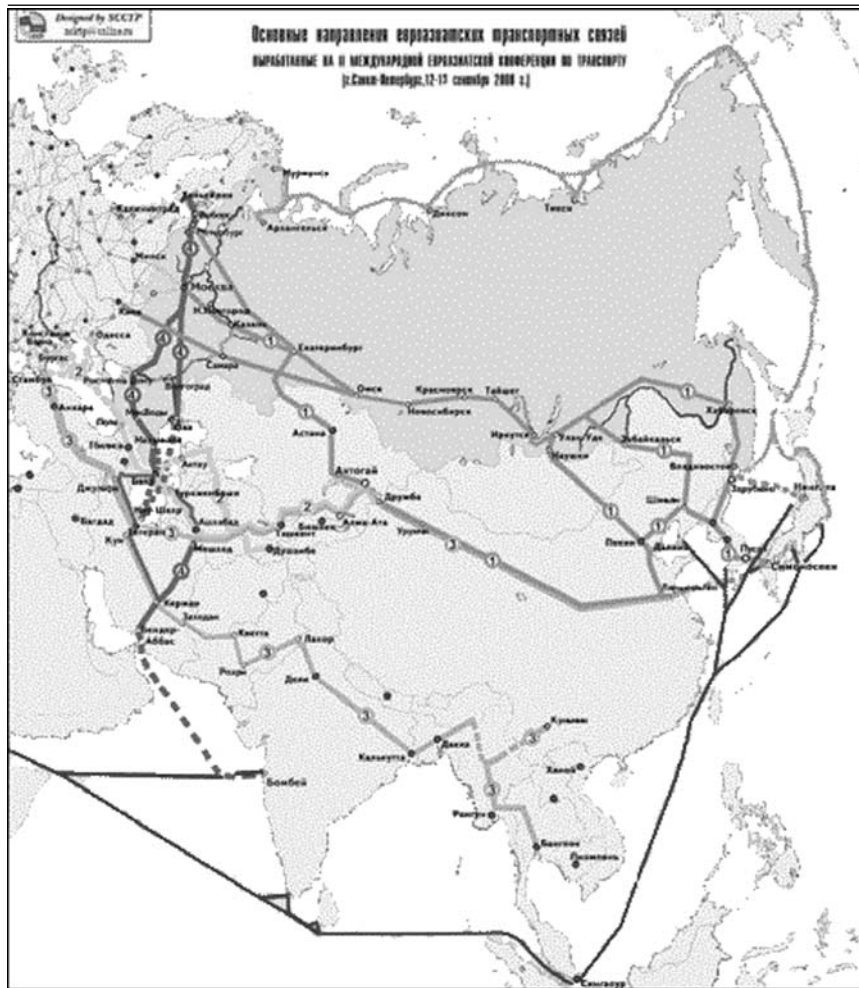

*Russia's Transport Ministry's plans are clearly intended to make Russian rail lines the center of Eurasian East-West traffic, and also to create a new North-South Corridor (at left) from the Baltic Sea to the Indian Ocean.*

ing of wide-gauge rail lines into North Korea and Central Europe.

This year, steps are being taken to increase the connections of Belarus and the Czech Republic to the Trans-Siberian. On Oct. 12, the first stage of a project to construct a latest-technology logistics “hub” at Bohumin in the Czech Republic will be launched, in cooperation with the Czech Republic and Ukraine. As a result of these measures Eurasian rail transport is already demonstrating that it is considerably more efficient than maritime transport.

In addition, Russia is emphasizing cooperation with China and Northern Europe. Container block trains now run from Beijing via Russia to Poland and Finland, and routes are being extended in all directions. Indeed, Russia wants to extend its wide-gauge rail lines—the standard in Russia and

the Commonwealth of Independent States (CIS) nations—into North Korea and Central Europe. With the existence of modern, efficient equipment to automatically change gauges on trains—already in use on the border between Spain and France—this should not constitute a problem to increased traffic.

A South Korean delegate reported that his country has just completed the section of the North-South rail link, right up through the Demilitarized Zone on the border with North Korea. If the Russian initiative is fruitful, rail and sea links could greatly expand traffic all the way from Western Europe to Japan.

**Russia-China Transport**

Russia and China have already established a rail container corridor from Beijing to Moscow, running three times a month, and this route has been extended to Poland and Finland.

However, the Russian railways have a massive task before them. Ten years of shock therapy have taken a severe toll. Transport volume had fallen by 50% until recently, though it is now increasing. The functioning of the planned economy to organize freight transport, whatever its limits may have been, now has to be replaced by the “market” system—something which has hardly succeeded in Western Europe. But the Russian government is committed to increasing freight traffic, which was 285 million tons in 2000, threefold by 2010.

One irony of the current state of international relations, emerged from the presentations of two highly qualified technical speakers, one from the Russian Ministry and the other from the U.S. General Electric corporation. Although in different contexts, both speakers pointed out how very similar are the overall conditions, including geography, weather, and distance, of Russia and the United States and Canada. But Russia transports 81% of its freight by rail; Canada, 73%, and the United States, 50%. In length of rail lines, the first is the United States, the second Russia; in ton-kilometers, the first three nations are the United States, Russia, and China, followed by Canada and India. For passenger transport, the leader is China, followed by Japan—which, however, only transports 5% of its freight by rail—and Russia, with the United States far behind.

# Pakistan Gets A Little Financial Relief . . . But Nothing More

by Ramtanu Maitra

On Sept. 22, Washington announced it was lifting the sanctions imposed against Pakistan in 1990 and 1998, preventing procurement of American arms and nuclear-related technologies. (The 1999 sanctions imposed by Washington after the October 1999 coup by the present military ruler, President Gen. Pervez Musharraf, have not been lifted yet.)

Lifting the sanctions, however, will not provide Pakistan with any immediate financial benefit, but will allow U.S. manufacturers to sell to Pakistan. What is designed to help Pakistan financially, is an economic package that is expected to be finalized early in October.

The lifting of sanctions, although discussed for months, materialized after General Musharraf decided to officially abandon the Taliban regime of Afghanistan and throw his lot in with Washington. Washington indicated it would offer some financial package soon to ease Pakistan's financial problems. Pakistani Finance Minister Shaukat Aziz was scheduled to be in Washington in early October.

It is evident that Pakistan, which helped in building up the Taliban and supported it through thick and thin, had little choice but to accept the American offer. Islamabad, however, will have to pay dearly, probably with many lives, if the offer is inadequate or not delivered quickly.

## Desperate Economic Straits

To say that Pakistan's economy is in dire straits, is an understatement. It has a foreign debt of almost \$36 billion, and debt service costs of \$7.8 billion annually. Pakistan's average debt service on foreign debt, at 64.9% of total foreign-exchange earnings, is higher than that of the UN-designated Heavily Indebted Poor Countries.

Over the years, the ratio of Pakistan's real imports to Gross Domestic Product has gone down dramatically, and yet, it incurs huge trade deficits annually. GDP growth, which averaged about 6% in the 1980s, is now close to 2.5%. Poverty has gone up during the same period, from 23.2% to 40.1%. Illiteracy is close to 75%. The nation is awash with drugs, arms, and violence. There is little, really, which indicates that Pakistan can put its economy back on track.

During the last three years, Pakistan had been running from pillar to post to get its foreign debt repayments resched-



*Pakistan's President Gen. Pervez Musharraf: A collapsed economy and U.S.-led sanctions have forced him to walk a very dangerous tightrope.*

uled. The International Monetary Fund (IMF), which goes through Pakistan's books with a fine-tooth comb, has recommended the donors to allow rescheduling of debt payments. But that came with a number of conditionalities.

As soon as General Musharraf agreed to provide support to the United States against the Taliban, the United States announced rescheduling of \$379 million in debt. More such relief is in the pipeline. It is also expected that Pakistan, which owes the United States more than \$3 billion, will be allowed to reschedule the entire debt. Such benefits will also be flowing in from Japan, the Asian Development Bank, and the IMF, Islamabad expects.

These measures have been welcomed widely in Pakistan, and outside. But the fact remains that it is not the shortage of cash that created the financial crisis Islamabad faces today. In the 1970s and '80s, Pakistan was flush with money, but the money was not invested to alleviate poverty, build infrastructure, or educate people.

Democratic governments, and the military rulers, dipped heavily into the public treasury, lining their pockets and using the money to prolong their political and military careers. This had been the pattern, and neither Washington nor anyone else could be blamed for these follies and mischiefs. Now, the situation is different. The IMF is demanding the reduction of fiscal deficits and, in essence, a further shrinking of the economy.

Donors are demanding that their debt be repaid, and the Pakistani President is going from country to country, seeking financial help. The coming days will be testing days. Investors will continue to shy away from a turbulent Pakistan, which is expected to become the center of a maelstrom if Washington chooses to invade Afghanistan, dragging Pakistan along. It is likely the ranks of the militants will grow swiftly, and capital will leave the shores of Pakistan faster than it arrived. Pakistan will require a lot more than what Washington is offering, to get back on its feet again.

A NEW GUIDE FOR THE PERPLEXED

## How The Clone Prince Went Mad!

by Lyndon H. LaRouche, Jr.

September 10, 2001

*The following was originally composed on the day preceding the terrifying events of Sept. 11. In light of the wild disinformation-campaign being conducted, around the clock, by CNN and other leading U.S. news media, what is written here has a quality of importance best termed "urgent." The way in which a mass-delusion is being willfully fostered by a lying mass-media, must be understood scientifically from the standpoint outlined below. I have amended the original draft of this report accordingly.*

*Consider this, then, for what it was originally intended to become: a technical manual, a guide for the perplexed, which is supplied to assist counterintelligence specialists and relevant others in overcoming the perplexities of the presently onrushing, profound changes in the world's order.*

In my review of the case of the hypothetical "clone prince," I summarized the evidence showing that there is a fundamental, which is to say axiomatic, quality of difference between human and animal behavior.<sup>1</sup> Typically, in all successful phases of cultures, human behavior is dominated increasingly, by the genetic-like influence of the individual's acquired memories of those mental acts which are functionally equivalent to an experimentally validated discovery of a universal physical principle.

Such memories are *not* deductive images of the footprints left by an act of discovery. They could never be reduced to sets of algebraic equations and diagrams written on a blackboard. They are, rather, memories of the unfolding process of that process of discovery as such.

They are like well-performed Classical musical compositions of the series

---

1. Lyndon H. LaRouche, Jr., "The Case Of The Clone Prince," *EIR*, Sept. 21, 2001, pp. 62-64.



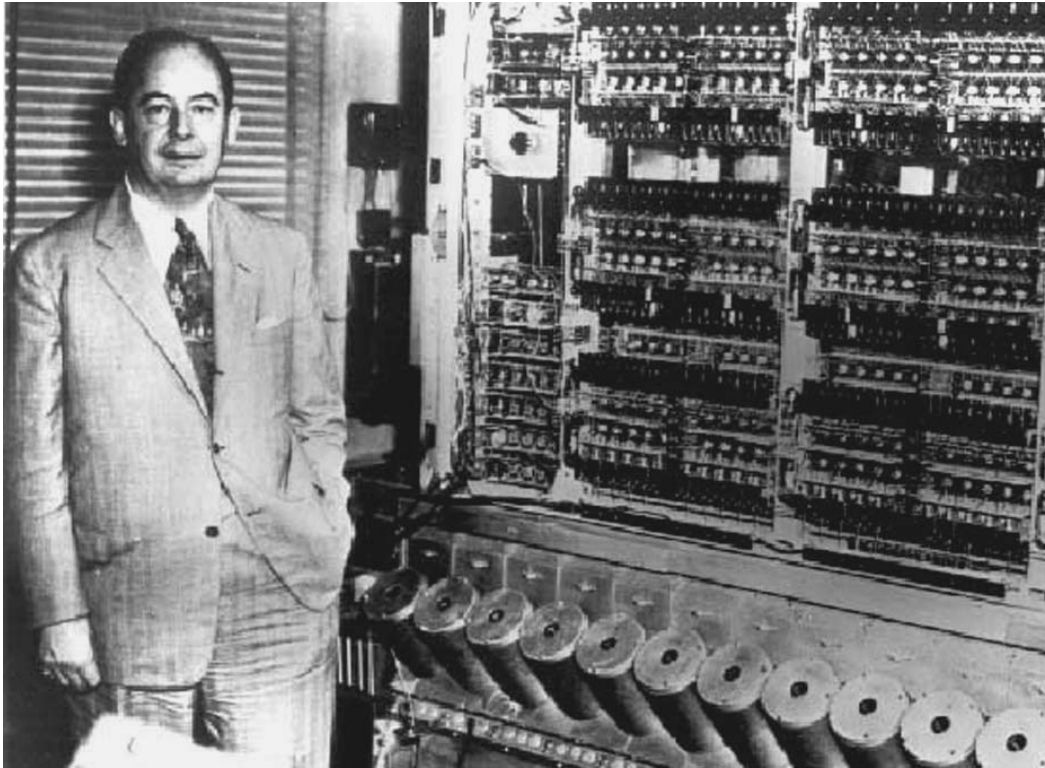

*John von Neumann, the putative founder of "systems analysis," typifies the type of deranged person whose widespread influence today is leading our society toward self-inflicted doom.*

begun with the work of J.S. Bach: an unfolding process of self-development, a perfect unity, which, from beginning to close, remains functionally not divisible into parts.<sup>2</sup> *Each discovery is a memory of the experiencing of a relevant cognitive process, not of a thing.* It is not an ensemble of sense-perceptions; it is a definite, but *monad-like* object of cognitive thought. Do not let that term, *monad*, frighten you; I shall explain the significance of that functional distinction, at a suitable place, below.

However, as I have emphasized, repeatedly, over recent decades, in addition to their inclusion of some valid such principles, most cultures are also permeated with false principles, arbitrary assumptions which the victims express as habituated beliefs, false beliefs which are used as substitutes for valid universal principles.<sup>3</sup>

Those victims treat such habituated false beliefs as if they had been acquired as discoveries of valid universal principles. In reality, such beliefs are not merely false, but are counterfeits of true discoveries; they are mental behavior of the type we rightly call "delusions." Such false principles produce

2. The learned idiot plays the notes of a musical score; the Classical artist performs what the composer conceived as the music to be performed between the notes.

3. Typical lying of this sort, is often accompanied by the fraudulent statement, "These are my principles," when the speaker knows, or should have known, that he has no truthful proof of his argument. Another variant on the same art of lying, is: "Are you questioning my sincerity?" Not his sincerity; merely pointing to his lack of honesty.

pathological effects which I have sometimes identified as "the goldfish-bowl syndrome." In cases corresponding to that "goldfish-bowl syndrome," the victims of such delusions limit their actions to choices which lie within certain imaginary boundaries, boundaries defined by false, axiom-like, ideological assumptions of induced blind faith.

In the annals of science, the most notorious among the deranged persons so defined, is the "perfectly logical" professor at the blackboard, who insists that proof of the mere deductive consistency of his "ivory tower" system, is a perfect substitute for the aspect of the physical universe which the professor claims his concoction to describe. The most extreme expressions of that pathetic state of mind, the expressions sometimes the most dangerous to society, are usually found either among certifiable lunatics, or, among mathematicians, such as the Bertrand Russell apostle, and putative founder of "systems analysis," John von Neumann.

The Christian Apostle Paul's denunciation of "single-issue morality," as in his *I Corinthians* 13, should be accepted as a warning to the credulous victims of such popularized delusions. Hans Christian Andersen's famous fable of "The Emperor's New Suit of Clothes," illustrates the way in which such mass delusions express themselves as "popular opinion."

## How Romantics Die

Large-scale social systems which cling stubbornly to such delusions, doom themselves over the course of time. This self-inflicted doom may unfold over centuries, as in ancient

Rome. It may sometimes unfold in the short run, or over one or more generations, as the fascist systems of Adolf Hitler and Benito Mussolini did. The presently onrushing collapse of the global monetary and financial system, began in the United Kingdom, as the first government of Labour Prime Minister Harold Wilson led that monarchy into the catastrophic sterling collapse of Autumn 1967. Changes similar those introduced under Wilson, were already in progress inside the U.S.A. by the mid-1960s. The result was not only the U.S. dollar crisis of January-March 1968; the same self-destructive trend in policy-shaping, was consolidated to become a dominant factor in U.S.A. policy-shaping over the 1966-1981 interval of U.S. political history.

This long-term downturn in the U.S. economy, began with Richard Nixon's pro-racist "Southern Strategy" campaign of 1966-1968 and his August 1971 wrecking of the world monetary system. The wrecking of the U.S. economy during one term of the disgusting President Jimmy Carter, was more destructive than under the nearly two terms of Nixon's Presidency. These terrible, axiomatic errors introduced over the 1966-1981 interval, have continued to destroy the U.S. economy, and much of the rest of the world, ever since.

For such reasons, the 1969-2001 collapse, is to be compared with the self-inflicted ruin of the Roman and Habsburg empires. It is among the notable examples of a collapse-cycle built into the intrinsically pathological axiomatic assumptions of a large-scale social system.

As I shall show below, all so-called "free trade" and related social, political-economic systems, are similarly doomed, as the case of the present world monetary-financial collapse demonstrates.

I emphasize a point I have made repeatedly in other writings and oral argument. Ask yourself: what is the power of popularized delusions over the mind and will of both individual persons, and even over the ruling establishment of self-doomed entire nations? The answer is: it is the lust of the individual to bask in the coddling warmth of popularized prejudices, such as popularized delusions of an axiomatic character. "None of the people I respect would agree with you," is typical of the way in which a self-doomed individual, or even a nation, will cling with passion to the delusion which dooms it, like a drowning man clinging to a sinking ship's anchor. It is the all-too-typical present-day politicians' predilection for kissing the foot of popular opinion, no matter how disgusting that fouled foot might be, which is the most commonplace form of moral corruption of contemporary, day-to-day political processes of government.

As a result of such passions, a people, a nation, such as Germany ruled by Adolf Hitler, may ensure its own ruin, even the destruction of its very existence. The currently widespread blind faith among the U.S. population, that a systemic financial crash is either not going to occur at all, or the wishful conceit, that any financial crash must soon rebound with a recovery, is typical of that same class of popularized delu-

sions. *This, for example, is the susceptibility to popular opinion on which today's U.S. "Big Brother," the mass-media, depends for its usually successful "brainwashing" of the majority of the U.S. population, and also the majority of those in the highest positions of our leading political parties, and government, today.*

A manifold of combined true and false beliefs of that axiomatic quality of effect, constitutes what is sometimes referred to as a "mind-set." Here, in this report, we are contrasting the characteristic, functional differences between sane and delusion-ridden mind-sets. Our emphasis is on the cases of mass-delusions underlying the rise and fall of entire social systems. The inevitable, now onrushing disintegration of the presently self-doomed, global monetary-financial system, is an example of such mass-delusions.

In other words, not only are so-called principles introduced, which originate in nothing other than deliberate falsehoods; the same "intuitional," specifically human, creative faculties of cognition, by means of which valid discoveries of universal physical principle are generated, are often misused by recklessly careening minds, to create ignorantly concocted, pathological pseudo-principles. The controlling mind-set of the individual victim of such induced mass-delusions, treats his or her such arbitrary, experimentally baseless beliefs, as if they were infallible universal principles. It is usually sufficient for that dupe of so-called "herd instinct," that he believe such beliefs to conform to popular opinion.

I shall show that the presently accelerating disintegration of the 1971-2001 world monetary-financial system, is an outcome of just such a quality of pathological mental behavior on a mass scale. In other words, belief in that system, is an example of a mass-delusion, a mass-psychosis.

In the field of strategic and related political analysis, a field in which I have become exceptionally successful in recent decades, an understanding of the characteristics of such induced mind-sets, is the indispensable basis for competence in long-range, global economic forecasting. These same methods of inquiry are also more or less indispensable in all aspects of political-intelligence investigations, such as the attempted *coup d'état* in progress, set into motion by the events of Sept. 11.

Properly developed and applied, these methods enable the qualified practitioner to foresee the inevitable characteristics of the long-term consequences of a persisting form of defective mind-set, *if not to foresee the exact, specific choice among such consequences, which the victims will choose to bring upon themselves.*

These methods are indispensable for making sense of the world-wide crisis descending upon all of humanity today. No competent assessment of the present U.S.A. and global crisis could be made in any other way. I have published much on this subject over recent decades. I summarize the momentarily most relevant elements of that argument here. These methods are indispensable for defining the changes in policy which

must be adopted, if a culture is to be saved from what is otherwise its inevitable, self-inflicted ruin.

To demonstrate these distinctions, I have often found it convenient, pedagogically, to show that the belief in so-called “Newtonian mathematical physics” is such a widely popularized delusion. I introduce the notion of the function of mind-sets in mass behavior, by defining the meaning of “systems.” For that reason, I begin with the case of the widespread academic pathology known as the cult of Sir Isaac Newton. After that, I show how that overview of the nature of systems must be applied, to understand the current mental state of the majority of the population, and leading circles, of the U.S.A. and many other nations today.

---

## 1. The Cult Of Isaac Newton

---

Britain’s famous monetarist John Maynard Keynes, after studying the contents of the so-called scientific papers found in Sir Isaac Newton’s chest, characterized Newton as a shameful, anti-scientific creature, whose beliefs should be classed as echoes of the ancient Mesopotamian abacadabrist. Keynes did not exaggerate. The origins of belief in the fantasy-universe of Sir Isaac Newton, may be traced back as far as the fanatically irrationalist forms of ancient cults of Delphi, the Eleatics, the sophists, and the Aristotelean method of Claudius Ptolemy, or to the cult of William of Ockham in medieval times.

The more immediate, specific origin of Newton’s delusion, is the Ockham admirer Paolo Sarpi, who, together with his lackey Galileo Galilei, gave England the naked, raw empiricism of Sir Francis Bacon and Thomas Hobbes. Out of the fog end of Seventeenth-Century empiricism, decadent elements in the U.S. population acquired that modern American pragmatism of William James, John Dewey, and Walter Lippmann, which has dominated U.S. policy-shaping, increasingly, over the course of the Twentieth Century. The presently pathetic state of mind of the majority of U.S. society, has been spewed from that latter source.

Apart from the contrary influence of President Franklin Roosevelt, the delusions typical of American pragmatism have dominated the U.S.A., since the successful, 1901 assassination of U.S. President William McKinley brought the notoriously pro-Confederacy figures Theodore Roosevelt and, later, Ku Klux Klan fanatic Woodrow Wilson, into the Presidency.

Galileo follower Newton typifies the empiricist influence of not only Bacon, Hobbes, Locke et al., but also Descartes, and Descartes’ admirer and aging Newton’s controller, the same, Paris-based Abbot, Antonio Conti, who also virtually invented that notorious pro-Newton, anti-Leibniz fanatic, Voltaire. The version of empiricism spread by the Venetian Conti and his Europe-wide network of salons, such as the circles of the hoaxsters Maupertuis and Leonhard Euler in

Berlin, subsumes the entire sweep of the fanatically irrationalist French and British “Enlightenment” of the Eighteenth Century, and also of the sickly Nineteenth-Century Romanticism of Immanuel Kant, G.W.F. Hegel, and their followers, up to the present time. The cult of Newton, and its corrupting influence on science, to this day, is typical of that specific trend in moral and intellectual corruption pervading the culture of globally extended, contemporary European civilization.

These generically Romantic,<sup>4</sup> Eighteenth- and Nineteenth-Century influences represent, taken together, the core of the ideology which is chiefly responsible for all of the principal horrors contributed to humanity as a whole by Twentieth-Century European civilization. Such is the continuing character and effect of empiricism, in its role as a pandemic cultural disease, up to the present moment of that civilization’s presently onrushing, existential crisis.

Therefore, it is not only urgent that we focus on the exemplary problem of Newton’s empiricism; we are aided in this work by the fact, that the crucial evidence of empiricism’s mass follies is so clear over the course of these recent centuries. That evidence should compel thoughtful people to ask themselves: Why do even many scientists defend the obvious absurdities of Newton’s “system,” still today? The answer is, the popularity of Newton reflects nothing so much as the cancerous influence of that legacy of ancient Rome, the cult of *vox populi*, more popularly known today as “popular opinion.”

Many typical victims of the Newton delusion passed their courses in secondary schools and universities, through accepting mindless drill in Newtonian and kindred systems. This was usually a condition of passing their courses, securing their university degrees, securing their professional employment, and surviving that modern inquisition known as the Babylonian (“babble-on-ian”)—like priesthood of the “peer review” committees controlling most science-related publications.

As a result of such brainwashing, even gifted experimental scientists, even those with important, experimentally verified discoveries to their credit, were often impelled to babble at the blackboard, in their effort to defend their discoveries in terms acceptable for presentation in the relevant, “babble-on-ian” peer-review proceedings. The contemporary cases of duped followers of Bertrand Russell clones Norbert Wiener (“information theory”) and John von Neumann (“systems analysis,” “artificial intelligence”), or the recent decade’s substitution of intrinsically incompetent “benchmarking” for

---

4. I use Romanticism in the strict, technical sense of the term. So used, Romanticism means, specifically, the cultural heritage which ancient Rome bequeathed to feudal and modern Europe; it means a cultural heritage which is not only wholly inconsistent with, but antagonistic to the Classical form of the Greek-Hellenistic heritage of Solon, Plato, et al. This distinction is clarified, step by step, in the course of the following pages.



*“Why do even many scientists defend the obvious absurdities of Newton’s ‘system,’ still today?” LaRouche asks. “The answer is, the popularity of Newton reflects nothing so much as the cancerous influence of that legacy of ancient Rome, the cult of vox populi, more popularly known today as ‘popular opinion.’”*

competent engineering, are typical results. This typifies the decadent academic product which today’s radical-empiricism-dominated, inquisitorial peer-review committees, prefer, increasingly, to misname “science.”

In contrast to the Newton cult, sane forms of modern science and its method, are traced principally from their roots in Plato’s Socratic dialogues. That tradition was introduced into modern European civilization through the founding of modern experimental physical science by Cardinal Nicholas of Cusa. Johannes Kepler founded comprehensive modern mathematical physics, on the basis of what he explicitly adopted as the basis in scientific method provided by such avowed followers of Cusa as Luca Pacioli and Leonardo da Vinci.

After Kepler, the list of most notable among the principal contributors to the development of competent forms of mathematical physics, includes Pierre Fermat, Christiaan Huyghens, and Gottfried Leibniz. Leibniz was followed by such notables as Abraham Kästner, by the French associates of the U.S.A.’s Benjamin Franklin, by the circles of France’s Gaspard Monge and Lazare Carnot, and by Germany’s Alexander von Humboldt, Carl Gauss, Wilhelm Weber, and Bern-

hard Riemann.

Focus upon the contrast between those two, mutually opposing views on the subject of systems: the so-called “Euclidean” view typical of the Newton cult, versus the modern science of Cusa, Kepler, Leibniz, et al. Keep in mind that our goal here, is to clarify the way in which not only economic, but social and philosophical systems, more or less predetermine those long waves in history which unfold over a generation or longer. The point is to indicate, that a nation’s fate can be changed, by an appropriate quality of willful change in its prevailing system of belief, its prevalent mind-set.

### What Is A System?

As I have emphasized in locations published earlier: within globally extended modern European culture, the conventional notion of the term “system,” is modelled upon what used to be generally accepted classroom Euclidean geometry. That system was defined by, first of all, a collection of interdependent definitions, axioms, and postulates, and, secondly, chiefly an array of those theorems which were derived, chiefly by deduction, from the initial set of axiomatic-like assumptions. Within the bounds of modern European civilization, the strict use of the term “system,” including “social systems,” reflects a notion based on comparisons to the image of Euclidean geometry as a taught system.<sup>5</sup>

The assumption, that the physical universe must be understood as lying within the bounds of those pathetically naive notions of sense-certainty, respecting space and time, which are associated with Euclidean geometry, is, in essentials, the characteristic feature of the cases in which a “Euclidean system,” such as that of Isaac Newton, is superimposed upon mathematical physics. This was the fatal flaw common to the otherwise mutually conflicting astronomical systems of Claudius Ptolemy, Copernicus, and Tycho Brahe.<sup>6</sup>

Within the domains of mathematical physics more broadly defined, the image of a “system” is an echo of the influence of rather narrowly defined Euclidean mathematical physics, but with the addition of some accompanying, specific changes in meaning. Two, mutually contradictory such variations in the definition of a mathematical system, are of leading importance for our topic here; the most important models

---

5. Modern reductionist algebra, as the case of Bertrand Russell illustrates this point, is, axiomatically, simply a degenerate reflection of Euclidean, or quasi-Euclidean geometry. NOTE: Nothing in the discussion which follows this point in this report, is to be read as implying that what is called today’s conventional classroom mathematics is not useful; as a practical matter, it can be indispensable, on the condition that you recognize the axiomatic outer limits of its validity. *It must never be used as a substitute for physical science.* That distinction will be illustrated in the section of this report addressing the categorical distinction between financial accounting and competent economics.

6. See Jonathan Tennenbaum and Bruce Director, “How Gauss Determined the Orbit of Ceres,” *Fidelio*, Summer 1998. See also an *EIR* special video production on this subject by Bruce Director, 2001.

for these contradictory variations are known as either “non-Euclidean,” or “anti-Euclidean” geometries.

The first variation, is the result of replacing some among the definitions, axioms, and postulates, but, without departing otherwise from the underlying assumptions of a Euclidean model. Typical of this, are physical systems consistent with so-called “non-Euclidean” geometries of Nikolai Lobachevsky and Janos Bolyai.

The second variation, is the result of challenging some among those assumptions underlying all systems consistent with either a Euclidean, or *non-Euclidean* model. Those notions of scientific method which reject all efforts to confine mathematical physics to either Euclidean, or non-Euclidean geometries, are therefore known as *anti-Euclidean* systems.

The work of Gauss’s teacher Abraham Kästner, is typical of systems consistent with anti-Euclidean models.<sup>7</sup> Bernhard Riemann’s revolutionary, 1854 habilitation dissertation, defines the essential principles of all *experimentally verifiable anti-Euclidean forms of physical geometry*. The model on which this present report is based, is what might be termed my own neo-Riemannian model for a general anti-Euclidean system.

Kästner emphasized that, rather than attempt to improve upon Euclidean geometry, as the advocates of non-Euclidean geometry do, we must challenge the assumptions which underlie each and all of the definitions, axioms, and postulates of that system. Gauss’s student, Riemann, carried forward Kästner’s policy in Riemann’s own, original, 1854, specifications for an anti-Euclidean geometry. In that dissertation, and later, Riemann expelled from science all unproven kinds of so-called “self-evident” definitions, axioms, and postulates, including those of the Euclidean and non-Euclidean geometries.<sup>8</sup>

In place of all arbitrary (e.g., so-called “self-evident”) definitions, axioms, and postulates, Riemann restricts axiomatic notions of an extended magnitude, to experimentally verified universal physical principles as such. In place of the space-time-matter dimensions of a Euclidean or non-Euclidean design for mathematical physics, he allows only experimentally validated universal physical principles as “dimen-

7. Abraham Kästner was not only the teacher of both Gotthold Lessing and of Gauss, but the central figure, behind the work of Lessing and Moses Mendelssohn, in the launching of the late-Eighteenth-Century German Classicism which was the chief opponent of the empiricist French and British Enlightenment of such Antonio Conti followers as Voltaire, Maupertuis, Leonhard Euler, et al.: But for the connection between the Leibnizian Kästner and Lessing, the modern English-speaking world would have never known the real William Shakespeare, nor the German Classical drama of Lessing and Friedrich Schiller, nor the anti-Romantic, Classical poetry of John Keats, Shelley, Goethe, Schiller, and Heinrich Heine.

8. “Über die Hypothesen, welche der Geometrie zu Grunde liegen,” *Bernhard Riemanns Gesammelte Mathematische Werke*, H. Weber, ed. (New York: Dover Publications reprint, 1953). It has become traditional in the so-called scholarly community, to term Riemann’s geometry as non-Euclidean, that in defiance of the plain language of his dissertation’s opening paragraphs.

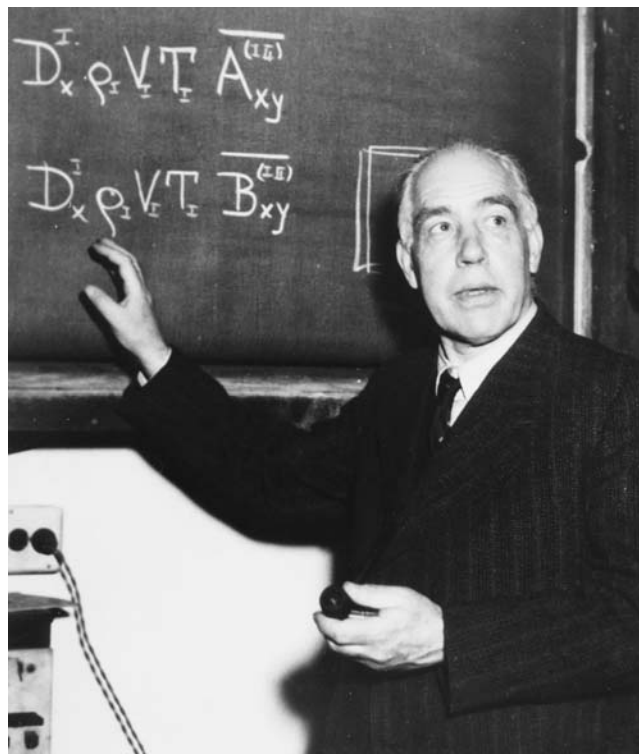

*Brainwashed scientists, such as physicist Niels Bohr, babble at the blackboard in defense of the “babble-on-ian” priesthood of peer-review proceedings.*

sions” of physical geometry.

Implicitly, in Riemannian physics, space and time themselves exist only in the form and reciprocal relationships which are implicit in verified discoveries of universal physical principle. So, as the successive work of, among others, Fermat, Huyghens, Leibniz, and Bernouilli, defined and refined a general notion of isochronic action in relativistic space-time. Hence, Riemannian relativistic physics. So, it is to be said that Riemann restricts the measurement of the characteristic relationships among such magnitudes, to experiment, explicitly excluding all “at the blackboard” mathematics *from use as a substitute for experimental physical science*.

The destructive impact of the post-1989 popularization of so-called, computer-based “benchmarking,” as a replacement for competent, traditional standards of engineering-design practice, is an example of the way in which the popularization of “at the blackboard” algebra has been adopted as a pathetic replacement for science.

My original discoveries go beyond Riemann’s specific argument. I concur with the Vladimir I. Vernadsky who defined the *biosphere*, and distinguished the biosphere as such, from the changes imposed upon the universe by human cognition. He identified the effect of the latter changes as the *noösphere*. However, my own view features two elementary considerations lacking in Vernadsky’s published work.

# The Keplerian Revolution

*In pathological mathematical methods, such as those used by the followers of Ptolemy, Copernicus, and Tycho Brahe, physical processes are merely described by the method of connecting observed points (“dots”) in ways which presume that all observed processes can be explained mathematically, as if at the blackboard. The diagrams shown here are from Kepler’s New Astronomy.*



**Claudius Ptolemy**  
(2nd Century A.D.)

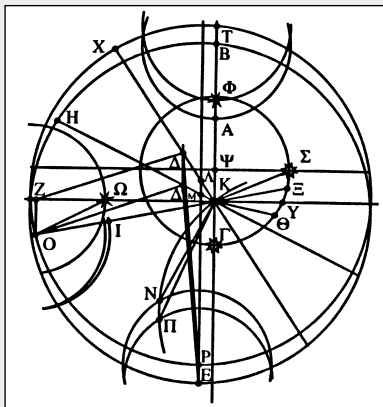

*The diagram is Kepler’s representation of Ptolemy’s geocentric worldview. The Earth is at point K; the Greek letters show the paths of the apparent motion of the Sun and other heavenly bodies, travelling around in epicycles. These were purely geometrical constructs, required to “save the appearances”—or permit prediction of astronomical phenomena. Ptolemy made no claim to describe the physical reality which would make such bizarre movements possible.*

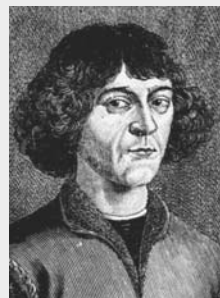

**Nicolaus Copernicus**  
(1473-1543)

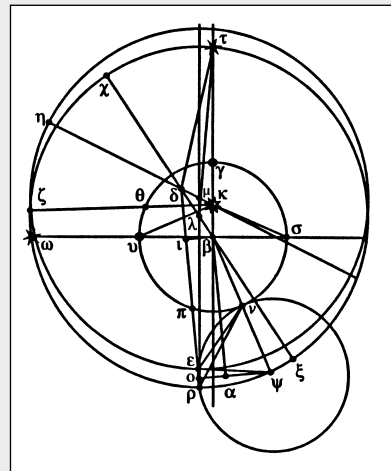

*His model of the cosmos moved the Sun to the center (at K), but still required a plethora of epicycles in order to “save the appearances,” because it was not based upon understanding of the physical causes of the motion of the heavenly bodies.*



**Tycho Brahe**  
(1546-1601)

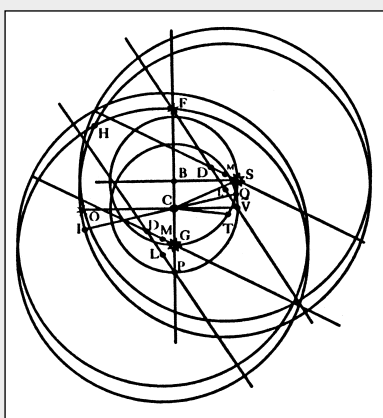

*Tycho’s construct was an attempt at a compromise between the Ptolemaic and Copernican models. The stationary Earth is at C. The Sun (S) revolves around the Earth, as do the “outer” planets (Mars, Jupiter, Saturn); the “inner” planets (Mercury, Venus) revolve around the Sun.*



**Johannes Kepler**  
(1571-1630)

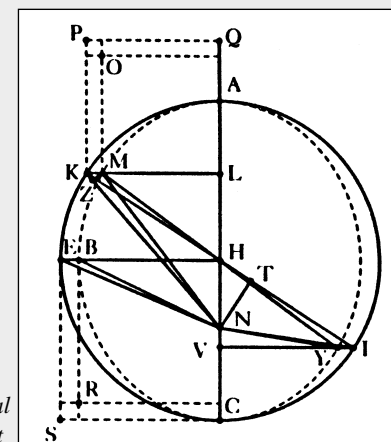

*For Kepler, the trajectory of action is determined by universal physical principles, not by “connecting the dots.” This diagram is one of many in the New Astronomy, by which he charts his discovery of the elliptical orbits and the principle of universal gravitation.*

First, I have adopted the method of Riemannian physical geometry, as the necessary way of conceptualizing the universe in terms of a multiply-connected manifold of three mutually distinct—axiomatically distinct—classes of universal

physical principles: *non-living, life, and cognition.*

Second, where Vernadsky focuses upon the individual mind’s contribution to man’s mastery of nature, through discovery of universal physical principles, I specify the necessity



of a certain intervening step. I warn that man's mastery of nature does not occur simply through the action of the individual's discovery of an experimentally verified hypothesis. It occurs through the impact of an individual's discovery in changing the set of universal physical principles adopted by society.

A crucial feature of the shortfall in Vernadsky's definition of the *noösphere*, was his lack of familiarity with precisely those crucial features and implications of Riemannian physical geometries which I made central to the application of my own original discoveries of the 1948-1953 interval, those made within the domain of Gottfried Leibniz's science of physical economy.

To describe my discoveries and their application as a system, the following points are essential. I summarize here what I have elaborated in sundry published locations.

The standard reading of Euclidean geometry began, with the purely arbitrary assumption, that the correct notions of indefinitely extended space and time, are to be intuited by blind faith in one's own senses. The Euclidean's, and Newtonian's deluded belief in so-called "self-evident" definitions, axioms, and helping postulates, should be recognized as reflecting childish blind faith in sense-certainty.

The following types of false assumptions are thus intuited from that latter delusion.

The first false assumption is, that space and time are each extended, as if in straight lines without limit. Thus, on that assumption, all the real occurrences whose effects are presented to us through our senses, are misstated in terms of relations among points.

Therefore, we must focus upon the commonplace, intuitive, pathological, classroom and other meaning assigned to the notion of an abstract, mathematical "point." Much of the mental illness invading today's teaching of mathematical physics, is most readily identified in this popular delusion. That pathological, arbitrary belief in the elementary self-evidence of the existence of the geometric or algebraic point (and point-mass), is the crucial folly inhering in all efforts to adduce a mathematical physics consistent with Euclidean or analogous forms of geometry.

This issue of the conception of the physical nature of that which sense-certainty views as a self-evident point, is the dividing-line between science and the delusions of sense-certainty. The argument to be made runs as follows.

All sane mathematical physics, in particular, proceeds from a specifically contrary intuition. In fact, the elementary form of experience is not a point-like, inferred object of sense-perception, but, rather, is *change*. This is *change* as Heraclitus and Plato successively define the ontological concept of change, instead of a point, as elementary.<sup>9</sup> In other words, the irreducible element of existence is *change* as such, instead of

9. E.g., Plato, *Parmenides*.

the abstract point of Euclidean and related geometries and algebras. This distinction is the elementary difference between pathological systems, such as those of the empiricists and positivists, and those of healthy science.

In pathological mathematical methods, such as those used by the followers of Claudius Ptolemy, Copernicus, and Tycho Brahe, physical processes are merely described by the method of connecting observed points ("dots") in ways which presume that all observed processes can be explained mathematically, as if at the blackboard. Theirs is the same, nominalist assumption adopted, arbitrarily, by Euler, that the representation of physical motion, and the causes for that motion, are reducible, in the infinitesimally small, to either straight-line connections, or a very near approximation of such estimates.<sup>10</sup> All of mathematical physics premised upon that fanatically expressed, false assumption of mathematical determinism, as by Euler, and also by empiricists and positivists generally, therefore represents axiomatically linear systems, even when such are sometimes misnamed "non-linear systems."

In anti-Euclidean geometries, such as those of Riemann,

10. Leonhard Euler, *Letters to a German Princess* (1761). The bowdlerization of Leibniz's calculus, by the introduction of the "Cauchy fraction," reflects the influence of Euler, Lambert, Lagrange et al., in continuing Euler's insistence on linearizing the calculus.

## Kepler's Revolutionary Discoveries

The most crippling error in mathematics, economics, and physical science today, is the hysterical refusal to acknowledge the work of Johannes Kepler, Pierre Fermat, and Gottfried Leibniz—not Newton!—in developing the calculus. This video, accessible to the layman, uses animated graphics to teach Kepler's principles of planetary motion, without resorting to mathematical formalism.

**"The Science of Kepler and Fermat,"**

1.5 hours, EIRVI-2001-12

**\$50** postpaid.



**EIR News Service**

P.O. Box 17390

Washington, D.C. 20041-0390

To order, call...

**1-888-EIR-3258** (toll-free)

We accept Visa and MasterCard.

the underlying physical connection among occurrences and observed “dots” is governed by discoverable, experimentally verifiable universal physical principles. For Riemannian physics, each principle is a quality of Leibnizian *monad*. Each principle has its own characteristic quality of action, and all relevant principles interact, in the manner of Leibniz’s *monads*, in what Riemann identifies as a multiply-connected way.

The first approximation of a comprehensive such form of mathematical physics, was introduced by Johannes Kepler. It was Kepler’s work which prompted Leibniz’s uniquely original development of a calculus, and from which the mathematical physics of such Leibniz successors as Gauss and Riemann was derived.

In real science, principles are never adduced by “connecting the dots,” as if merely statistically. In real science, the trajectory of action is determined by universal physical principles, as this is illustrated by the process of discovery underlying Kepler’s original identification of a principle of universal gravitation. That was the discovery which exposed, and disproved conclusively the false method inherent in the astronomy of Ptolemy, Copernicus, and Brahe, for the case of systems of non-uniform curvature. The method adopted by Kepler, in overturning the false assumptions common to those three, provides the relatively simplest proof, that the reductionist definition of the abstract mathematical “point,” is false. This proof obliges science to return to the notion of the universality of change, as emphasized by Heraclitus and Plato. For that, we must examine the issue in a way which is more general than formal mathematics as such. See the same problem as it arises in music.

## Music As An Example

As I have emphasized in locations published earlier, there is an indispensable function performed by introducing certain matters of Classical well-tempered counterpoint to the discussion of the elements of physical systems. The operations of deductive-logical argument, which are usually regarded as the quality of thinking about mathematics, disregard the most essential feature of those mental processes through which the discovery and transmission of knowledge of verifiable universal physical principles occurs, the feature fairly identified as *passion*.

The ideologues of deductive mathematics take pride in their exclusion of the consideration of *human passion in general*. Admittedly, only a mentally deranged person would seek to resolve differences on the subject of mathematics, by symbolic trials in the bloody arena of bodily contact sports. Nonetheless, contrary to the famous argument of the morally deranged Immanuel Kant, there is a specific quality of human passion, without which the work of discovering and transmitting knowledge of universal physical principles could not occur. This specific quality of passion is not only essential for scientific discovery. As Kepler introduced the notion of the

*intentions* of the Solar System, for defining the principle of universal gravitation, passion, in the sense of *intention*, must be included by the mind as an integral part of the image of the physical universe outside our sense-perceptions as such. *This passion is not only characteristic of the act of discovery; it is also the essential internal quality, of intention, of that which is discovered.* The same quality of passion is intrinsic to Classical well-tempered counterpoint.

*A valid discovery of principle in physical science, is essentially, intrinsically, a work of love, the quality of love which Plato’s Socrates identifies by his use of the Greek term *agapē*.* This quality of *agapē*, is the active principle of composition and performance in all valid expressions of what is usefully distinguished as Classical artistic composition, as opposed to Romantic, modernist, and so on. It is typical of great Classical poetry and drama, and of such Classical products in plastic art-forms as the work of Leonardo da Vinci and Raphael Sanzio. In the non-plastic forms of Classical composition, the Classical method of well-tempered counterpoint, is the highest form of expression of this quality of action by the human mind.

Therefore, any competent discussion of those qualities of human reason which express cognition explicitly, must focus upon all of those products of human reason which express the fullness of the relevant cognitive process of discovery itself. This is in contrast to reductionist mathematical physics, which considers only the mere shadows of reality, as these might be projected on the mathematical formalist’s blackboard or computer screen.<sup>11</sup>

Therefore, let us look briefly at my foregoing argument against nominalism, this time from the vantage-point of J. S. Bach’s method of counterpoint, as clearly defined from his famous *Well-Tempered Clavier* through his *A Musical Offering* and *The Art of the Fugue*. This is the polyphonic method, of Bach, upon which all strictly Classical forms of musical composition, such as those of Mozart, Haydn, Beethoven, Schubert, Mendelssohn, Schumann, and Brahms are based. Close examination of the central physical principle underlying Bach’s discovery of well-tempered counterpoint, illustrates the way in which the cognitive processes of the individual mind, uncover the nature of that real physical world which exists beyond the limits of the nominalist’s interpretation of our senses.

The point to be made is situated as follows.

Bach’s method is rooted in the legacy of that same, Fifteenth-Century, Florentine *bel canto* mode of voice training also prescribed in scientific terms by the scientist, master builder, painter, and musician, Leonardo da Vinci. The root, in the physical universe as a whole, of Bach’s development

---

11. It has been reported that mathematicians tend to dream in black and white, whereas musicians tend to dream in color. That report is, at the least, approximately true. The best physicists I have known are often amateur Classical musicians, or, at the worst, avid lovers of Classical works.



*“There is a specific quality of human passion, without which the work of discovering and transmitting knowledge of universal physical principles could not occur,” writes LaRouche. Here, the late Prof. Robert Moon, who exemplified that quality in his pursuit of science.*

in counterpoint, is the way in which the naturally determined register-shifts, and related characteristics of trained human singing voices, are defined.<sup>12</sup>

Bach’s counterpoint begins with a paradoxical germ-principle of *change*, which must be stated, for comprehension, in terms of mentally heard human singing voices, each of exact human singing-voice species, in the minds of the composer and competent performer. Without focus upon the natural *bel canto* qualities of the trained human singing voice, great music does not exist. “Purely instrumental” music does not exist in the domain of civilized Classical composition and performance. Only instruments which are compelled to sing as *bel canto*-trained human voices do, could produce the effect known as Classical well-tempered counterpoint.

The composition as a whole, begins from the simple statement of the initial contrapuntal paradox. The composer’s mind hears this as sung by human, *bel canto*-trained voices, not a mere musical instrument. If it is composed for an instrument, the composer intends that the instruments shall be forced to imitate the qualities of the *bel canto*-trained human singing voice, and the performer must obey that intention. The origin of Bach’s method of well-tempered counterpoint, lies within the domain of the distinctive characteristics of the full chorus of *bel canto*-trained human singing voices.

It is the state of tension established by the initial announcement of the relevant contrapuntal paradox, which must grip the cognitive processes of the mind of the composer, performers, and audience from the outset. The minds so gripped must

never be let go, until the conclusion has been reached. Throughout the composition and performance, there is never mere repetition, but always change. Even when the printed score suggests repetition, the adequate performer and audience hear a crucial feature of change (such as a change in implied *bel canto* registration of the apposite element, through the implication of a substituted singing voice<sup>13</sup>), in the recapitulation or apparent imitation.

The unfolding composition is a seamless process of change, which resolves the paradox in the end, but also does something more than that. The effect, as is made most clear by Beethoven’s late string quartets, or Brahms’ *Fourth Symphony*, is to create a composition which has a distinct *personal* identity as a process of change. Similarly, the development of the great Classical composers, produces a distinct personality pervading all of their compositions. All of the compositions of great composers are implicitly in dialogue with the characteristic personality of the compositions specific to their own other compositions and also those of other great composers, and also each composition among their own.<sup>14</sup> The mind con-

13. As indicated by a recent lecture of an associate on this matter.

14. The simplest demonstration of this relationship among Classical composers and their compositions, is the revolution in musical composition launched, at Baron von Swieten’s weekly Vienna salon, through the study of van Swieten’s precious collection of the original manuscripts of J.S. Bach compositions. Here, the magnificently gifted Wolfgang Mozart mastered the art of composing fugues. Here, Mozart adduced an insight into Bach’s demonstration of the Lydian principle, in Bach’s *A Musical Offering*, which revolutionized the methods and principles of Classical musical composition. Mozart’s exposition of that principle, both in his six string quartets dedicated to Josef Haydn and his famous Köchel 475 *Fantasy*, became a kind of Rosetta Stone for all leading Classical composers from Mozart and Haydn, through Brahms. The examples in which these composers quote Mozart’s K. 475, including

12. This is explicitly contrary to the arguments of the irrationalists Rameau and Fux, and the hoaxes on voice-training and tuning perpetrated by Hermann Helmholtz and his lackey Ellis.

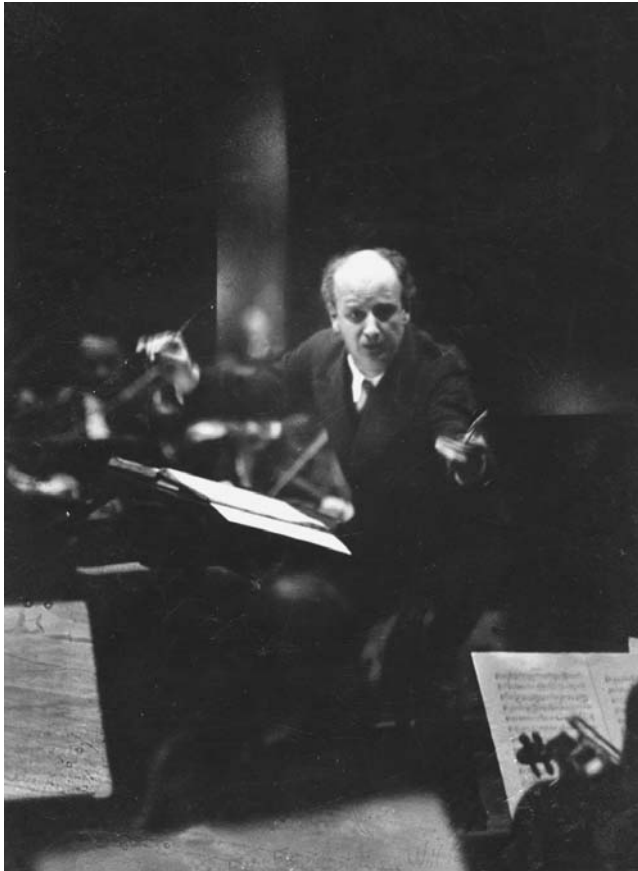

Wilhelm Furtwängler in Berlin, 1930. "Usually, the ability to perform a Classical composition with at least an approximation of Furtwängler's distinctive excellence, is rooted in a proper form of thorough grounding in the method of composition employed by J.S. Bach."

ceives each as an indivisible individuality, whose characteristic is a pervasive principle of change, a distinct notion of a change.

One of the most relevant controversies over the implications of this point, has been the back-and-forth on the subject of conductor Wilhelm Furtwängler's emphasis upon what is sometimes described as "performing between the notes."

Usually, the ability to perform a Classical composition with at least an approximation of Furtwängler's distinctive excellence, is rooted in a proper form of thorough grounding in the method of composition employed by J.S. Bach. In this

---

other compositions by Mozart himself, was the specific subject of a great dialogue among those composers, which, beginning 1948-1952, was one of two crucial experiences which opened up Classical music for me. The other was my first, stunned hearing, in early 1946, of a recorded performance conducted by Wilhelm Furtwängler. It was the overlapping implications of the K. 475 *Fantasy* and Furtwängler's method of "performing between the notes," which contributed in a crucial way, to my 1948-1952 original discoveries in physical economy, and my 1953 insight into the crucial importance of Riemann.

proper form, the score is heard as a chorus of *bel canto* singing voices, both of human singing voices and of instrumental voices which are forced to imitate a human quality of *bel canto* singing voice. This method, with its modal implications, is the basis for all great Classical musical compositions from Mozart and Haydn, through the exemplary Brahms.

Conducting and performance which are efficiently under such influences, is performed with a *special quality of passion*. It is that quality of passion, which enables the conductor and performer to reproduce a truly unified conception of the performed Classical composition as a whole.<sup>15</sup> The conductor, for example, has developed in his or her mind a unified conception of the composition as a whole, as if a single mental act of impassioned thought. This thought has the quality of a single, impassioned conception of *change as such*, rather than the mere succession of the score's notes.<sup>16</sup> The unfolding fabric of the performance as a whole, is made a process of emergence of the affirmation of that single, impassioned idea, at the close. Similarly, unless the attack upon the opening interval of the performed composition is efficiently so predetermined, the soul of that composition as a whole will tend to limp its way toward the close, if, indeed, it survives the journey at all.

*This notion of an impassioned process of change as an existent, indivisible unity*, is precisely equivalent to Leibniz's definition of what he terms a *monad*. Thus, in a competent performance of such works, the performer uses only the intended notes, but what he performs is the *monad*. A memory of the whole composition as a monadic unity, is the idea conveyed by a successful performance of the composer's intention.<sup>17</sup> The notion of the provable, efficient existence of a discovered universal principle, is also a *monad*. This definition of *monad* corresponds exactly to Plato's definition of an *idea*.

A well-performed great Classical musical composition, is essentially a form of Leibnizian *monad*. It is typical of all relatively higher-ranking qualities of such *monads*. It has a distinct identity, distinct from all similar compositions. This identity unifies the process of development which the composition as a whole expresses. Yet, each part of the composition is distinct.

The wholeness of that composition is its *existence* as a process of cognitive development. This process is inseparable from the specific quality of passion required for its composi-

---

15. The proper name for the performer who executes Bach differently than that, is not "musician," but, "mortician."

16. For a simple illustration of that point, compare Franz Schubert's *Wanderer Fantasy* with the re-arrangement of that work by Franz Liszt. Eliminating the excess notes added by Liszt, demonstrates, beautifully, the improvement so effected.

17. In a good or failed performance of a Classical score by a well-trained professional musician, the notes are the same, but there is a certain crucial difference. The critic familiar with the principles of Riemannian geometries would point out, that the two readings are performed within a different choice of the physical geometry within which the score is delivered as performance.



The late Eliane Magnan performs Bach. It is a special quality of passion, which enables both conductor and performer to reproduce a truly unified conception of the performed Classical composition as a whole.

tion and successful performance. However, that existence expresses varying relative values in each aspect of its development. This passion is identifiable as a quality of emotion, with the impulse which enables a scientific discoverer, responding to an ontological paradox in physics, to generate the verifiable hypothesis corresponding to the relevant, needed universal physical principle.

This argument is efficiently illustrated by comparing all of those numerous Classical compositions, of Wolfgang Mozart himself, and of Beethoven, Schubert, Schumann, and Brahms, among others, which explicitly quote the subject of Mozart's Köchel 475 keyboard *Fantasy*. Each of these, such as Beethoven's Opus 111 sonata, for example, is in a direct relationship with Mozart's *Fantasy*, and yet each of these has its own distinct personality, even when the cases compared were produced by the same such composer. Indeed, Beethoven includes a contrapuntally crucial kind of direct quotation from that Mozart *Fantasy* in the coda of the second movement

of the Opus 111. Each such composition is a distinctly sovereign personality in itself, a truly distinct musical idea.

Such musical examples also typify the meaning of the notion of the *monad* which Leibniz developed out of his exploring the implications of his discovery of the calculus. Leibniz's work, with Jean Bernouilli and others, on the elementarity of the catenary function for the calculus in general (**Figure 1**), points to the process of internal development of the calculus into a higher form of that calculus which subsumes the notions of *Analysis Situs*, a *monadology*.<sup>18</sup>

From considering this example provided by music, we are led to recognize the related requirement of a *bel canto* quality of sung musicality inhering in all Classical poetry; from this, we are guided to discover the way in which the greatest composers, such as Shakespeare and Schiller, produced their great compositions on the subjects of tragedy and the sublime.

When such considerations are placed in conjunction with the evidence provided by the application of Riemannian physical geometry to the principles and practice of physical economy, we are impelled to comprehend the universality of the notion of cognitive ideas, beyond the narrower bounds of today's academic mathematical-physics teaching as such.

### The Fallacy Of Sense-Certainty

The relevant, crucial illustrative fact underlined by that musical example, is the following.

In Riemann's system of physical geometries, extensible change is expressed in the form of an experimentally demonstrable universal physical principle of change. The universe then appears to the mind as a manifold of many such universal physical principles. These principles interact in what is called a "multiply-connected" way, to define a subsuming principle of universal change, which subsumes the combined effect of all of the physical principles it contains. This quality of universal change is measurable as a characteristic of action in that physical space-time, a characteristic whose value can be determined solely by appropriate types of experimental methods.

Since any Riemannian geometry is subsumed by the change embedded in a succession of such physical geometries, the reality corresponding to a Riemannian physical geometry of practice, is never a fixed geometry. Just as Kepler showed the action of a planet's motion to be subsumed by a higher order of determination, in the characteristics of the orbit considered as a whole, the higher order of geometry, including the cases of changes linking a series of geometries, determines the relevant, intrinsically non-linear value of the differential in the very small.

To similar effect, within any developed mathematical physics, for example, there remain uncorrected, false assump-

18. Thus, only poorly educated students, who have failed to grasp the general implications of this work on the catenary, mislocate the notion of an isochronic principle in the cycloid.



“Leibniz’s work, with Jean Bernoulli and others, on the elementarity of the catenary function for the calculus in general, points to the process of internal development of the calculus into a higher form of that calculus which subsumes the notions of *Analysis Situs*, a monadology.”

FIGURE 1  
**Leibniz’s Construction Of The Catenary And Logarithmic Curves**

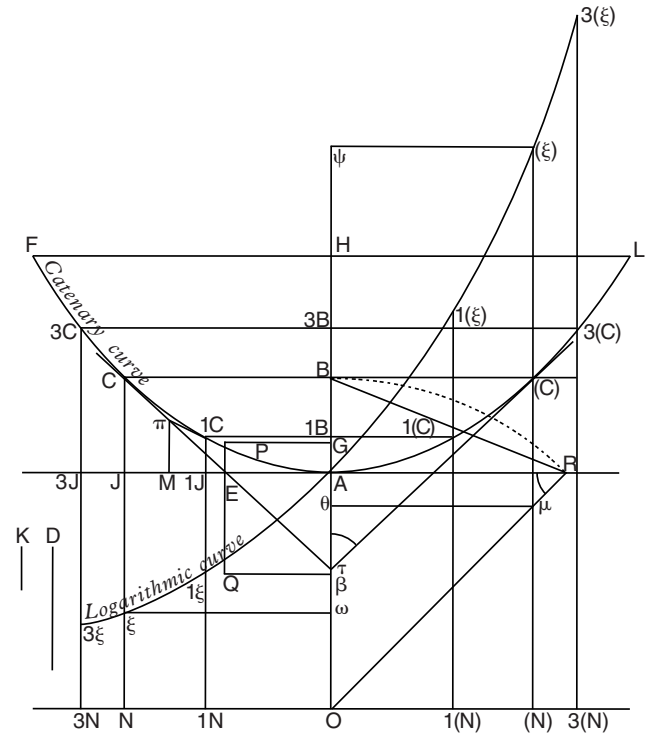

Source: *Fidelio*, Spring 2001.

tions parading as universal physical principles, which have yet to be removed. There are, also, far more numerous instances of principles which have yet to be discovered. Thus, investigation must consider both the experimental evidence of change inhering in the process under study, and experimentally defined changes in the methods by which the study is conducted. Both of these are propositions in Riemannian physical geometries.

The use of the term Riemannian geometry, or geometries, varies in relevant meaning and practice, according to the relevant context. On this account, we must recognize, first, a corresponding distinction must be made, between the universe as a totality, and a lesser part of that universe, a smaller number of dimensions, which we call a phase-space. We must also recognize distinctions between a Riemannian geometry, and an ordered series of Riemannian geometries. This notion of a series of differential Riemannian geometries, is crucial in discussing real-life economic processes, such as the evolutionary, or devolutionary physical-economic development of entire societies.

It is crucial to say, once again, that within that context:

since each addition of a true principle, or deletion of a false one, changes the manifold of mathematical physics, it were impossible to assign any final, fixed value to a significant differential. Just as the whole Keplerian orbit of Mars or Earth, determines the differential value subsuming an interval of that orbit, so, the apparent differential values must change, as our knowledge of the totality is improved, or, as we recognize the importance of avoiding excessive simplifications of the phase-space of reference.

Again, once more, as in the instance of Kepler’s recognition of the equal-angles-equal-times determination of the curvature of a planetary orbit, the conception of the existence of the integral calculus must precede the differential, axiomatically (**Figure 2**). It is the way of thinking about the relationship between wholes and their included moments, within entire processes, which points the mind to the indications of the existence of higher orders of entire processes in the ontological paradoxes which arise within the existing mathematical physics’ representation of the crucial-experimental domain of practice.

For example, it is through meticulous attention to the stub-



FIGURE 2

**Kepler's 'Area Law'**

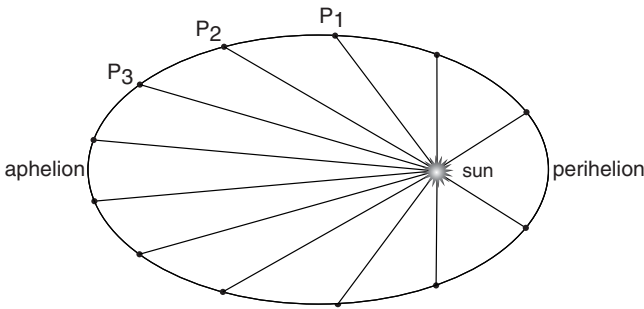

Source: *Fidelio*, Summer 1998.

*“It is through meticulous attention to the stubborn, but seemingly tiny margins of error contained within an assumed differential value, that Kepler discovered universal gravitation. Most important fundamental discoveries occur, through the agency of non-deductive cognition, in that way.”*

*Kepler proved, as the diagram shows, that in equal time intervals, the areas of the curvilinear sectors swept out by the planets, will be equal—even through the curvilinear distances traversed on the orbit are constantly changing. P<sub>1</sub>, P<sub>2</sub>, and P<sub>3</sub> are three successive positions of a planet.*

born, but seemingly tiny margins of error contained within an assumed differential value, that Kepler discovered universal gravitation. Most important fundamental discoveries occur, through the agency of non-deductive cognition, in that way. Hence, contrary to Euler, Lagrange, Cauchy, et al., no competent mathematics will attempt to impose a principle under which the differential is reduced axiomatically to linear approximations.

Each of a set of valid universal physical principles, and also the Riemannian quality of multiply-connected unity among them all, represents a *monad*, in Leibniz's sense of that term. Riemann's revolutionary discovery redefines the work of experimental mathematical physics in the manner implicit in Leibniz's interrelated notions of *Analysis Situs* and *monadology*.

In Riemannian physical geometry and its outgrowths, we distinguish chiefly among two qualities of experimental measurements. On the one side, we have the measurements which suffice for experimental proof of *existence* of a *monad*. This monad is comparable, conceptually, to the unique identity of a Classical musical composition premised upon Bach's well-tempered counterpoint. On the other side, we have the need to demonstrate the characteristic features of the changing measurable values for defining relations among *monads*. In other words, we must distinguish between the experimental evidence which defines the existence of an object, such as a microphysical object, and the measurement which defines

the relative location of that object in a particular physical-geometric setting.

The question of the existence of Planck's quantum, as Planck defined it in opposition to the Machians, is an example of the distinction which I am emphasizing here.<sup>19</sup> This produces the specific quality of paradoxical view of the universal experimental domain, the so-called *continuum*, which is the essence of fruitful scientific discovery.

Take as an example, Kepler's uniquely original discovery of universal gravitation. Kepler apprehends the Solar System as a functionally indivisible coherence, a unity of all Solar processes with the existence of its Sun. From apprehension of the way in which the planetary orbits are located with respect to one another and that Sun, Kepler adduces what Newtonian and other bowdlerizers have misnamed "Kepler's Three Laws." Kepler not only proves, experimentally, that no reductionist statistical analysis can account for the momentary position and velocity of the planet in its orbit; he proves that there exists a universal principle, independent of those statistical measurements, a principle which, in first approximation, expresses an acting principle of universal gravitation.

In a Euclidean, or a specifically non-Euclidean version of physical geometry, each and all of the characteristics of space and time, are fixed. Within that fixed system, everything discovered must be located within that intellectual, "ivory tower," mathematical image of physical-space-time. Thus, the essential definition of existence is implicitly degraded to something located in terms of points mapped in the manifold associated with that physical-space-time. In contrast to this, in Riemannian physical geometries, as in the science of physical economy, experimental science generally is focussed, *primarily*, on functionally ordered changes in the manifold itself which are associated with the axiomatically defined existence of universal types of objects.

Look at a discovery emphasized by Plato. As was emphasized for modern science by Pacioli, Leonardo da Vinci, and Kepler,<sup>20</sup> the physical implications of the fact of the uniqueness of the five regular Platonic solids, reflect, among other considerations, the distinctness of the system of living processes, as compared to non-living. This signifies, as Vernadsky poses the issue of the distinction of living processes' action in creating the biosphere, that the action of living processes on the abiotic, locks the abiotic material being transformed within a higher physical geometry, that of life itself.

19. See also L. Hecht, on Wilhelm Weber's discovery of the constant which correlates with the experimental proof of the Ampèrean angular force in electromagnetism: "The Significance of the 1845 Gauss-Weber Correspondence," *21st Century Science & Technology*, Fall 1996; pp. 21-43.

20. E.g., Luca Pacioli, *De Divine Proportione* (Vienna: 1896; Milan: Silvana Editoriale, 1982, facsimile of 1497); J. Kepler, "A New Year's Gift, or, On the Six-Cornered Snowflake" (1611) Colin Hardie, trans., Oxford University Press, reproduced by permission by 21st Century Science & Technology, 1991.

As a general observation, this illustrates the point, that it is an elementary blunder of incompetence in scientific method, to attempt to build up assumptions respecting the characteristic features of systems from observed trajectories in the small; rather, we must discover the nature and characteristics of the geometry in which those actions in the small are situated. For example: The laws of the universe exist only within the geometry underlying that universe in which we exist.

---

---

*The implied question is, “How can we know the difference between merely sensing an event, as by means of sense-perception, and actually knowing the object which is properly associated with that event?”*

---

---

The elementary, axiomatic difference between mere sense-certainty and actual knowledge, is an expression of the same distinction: *the significance of an action is shaped by the geometry of the process within which it occurs*. Thus, sense-perception represents one system, and the universe which is sensed, another. The relationship between these two respectively inconsistent systems can not be simply mapped; to resolve that paradox, we must introduce a third system, that of man’s intention to change the sensed existence of the system outside our sense-certainties. It is only through that third system, that the paradoxical juxtaposition of the different geometries of the sensory and real universe can be comprehended. My discoveries in the field of the science of physical economy address that problem in the only way an adequate insight could be developed.

Look again at what I have just stated about Riemannian physics, this time from the vantage-point of the fellow locked up in that prison called his sense-organs. That poor fellow is poor, both intellectually and morally, only because he is deluded by his conceit, that his organs of sense-perception are transparent windows of the soul, through which the universe outside is plainly displayed to all those who have learned to keep those windows polished and clean. This delusion defines the cult of what is called “sense-certainty.”

To restate what I have said on this point in earlier locations, contrary to the delusion called “sense-certainty,” our organs of sense-perception do not show us a simple copy of the universe outside our skins. Rather, they reflect the experience of the impact of the world, outside our skins, and also within it, on those organs of sense-perception as such. “Ouch!” is not something which exists outside our skin; but,

typically, the effect, of something outside our skin, touching those sense-organs housed within our skin.

The objection to be made against blind faith in sense-certainty, may be expressed, therefore, as a psychiatrist might: “I may accept the bare fact of an existence corresponding to what you report you have felt, but how do you know what caused that feeling? How do you know it was not the result of some mean trick played upon your sense-organs by little green men from outer space?” To meet the challenge of answering such questions honestly, without bluffing, or without simply changing the subject of discussion, we must supply a much stricter definition of “science” than is usually met in textbook or classroom. We must act intentionally on the real universe, to bring about, intentionally, an efficient, perceptible change in the way the world of sense-certainty behaves.

The implied question is, “How can we know the difference between merely *sensing* an event, as by means of sense-perception, and actually *knowing* the object which is properly associated with that event?”

### **The Definition Of Knowledge**

The known method for answering that question, is traced chiefly to Plato’s dramatic, Socratic dialogues as a source. A crucial improvement in that answer, is implicit in Leibniz’s definition of a science of physical economy.<sup>21</sup> It has been my historical good fortune, as a discoverer, but my personal misfortune as a contemporary political figure, until now, that an epistemologically satisfactory form of practical answer to that question, was lacking until my own redefining of that question, in my original discoveries in the science of physical economy. I have developed the relative elementary argument in published locations as follows.

That quality of knowledge we may rightly call “scientific,” has its origin in the recognition that experience has confronted us with occurrences which could not have occurred in a way which is consistent with the previously established system of opinion-making of a particular culture, nation, teaching, and so on. Such evidence obliges the believer in that system to consider the fact, that axiomatic assumptions which have appeared to explain certain kinds of events, fail to account for some stubborn evidence. Such is the significance of Plato’s Socratic dialogues, especially when these are taken as a unified whole, that when they are spoken, heard, and understood as Classical dramatic compositions expressing the principle of the sublime, as Friedrich Schiller, for example, famously defined the sublime.

As examples of this, I have frequently used the case of Kepler’s discovery of universal gravitation, as in his *New Astronomy*, and Pierre Fermat’s preliminary, experimental definition of the isochronic principle, that it is “quickest time,”

---

21. Some relevant English translations of short works by Leibniz are to be found in back-issues of *Fidelio* quarterly: “The Arts and Sciences,” Spring 1992; “Society and Economy,” Fall 1992.

rather than shortest distance, which governs the pathway of refraction of light. These types of experimental evidence present us with what is rightly termed, in the technical language of Classical epistemology, *an ontological paradox*.

The solution for such an ontological paradox, is the discovery of a verified *hypothesis*. By *hypothesis*, we signify an idea which has the quality, in form, of a universal physical principle. To qualify for the title of hypothesis, that idea must show either that some relevant axiomatic assumption of the believer was false, or that some additional axiomatic assumption, that of the hypothesis, would produce a new system of thought consistent with all of the relevant evidence. If a certain uniquely appropriate quality of design of experiment, shows that that hypothesis is universally correct, we adopt that hypothesis as a universal physical principle. The result of incorporating such an hypothesis as a universally efficient principle, in that way, is not merely the addition of a new universal principle to the system, but also a revolutionary transformation of the system itself.

Universal physical principles, and non-deductive transformations of systems, effected in that way, qualify as scientific *knowledge*, as distinct from, and opposed to sense-impressions. No knowledge was ever acquired, except by means of hypotheses defined as I have just summarized the functional meaning of the term *hypothesis*, contrary to the famous, silly aphorism of Isaac Newton. Examples include the discovery of the principle of universal gravitation, which Kepler discovered, and Newton ineptly plagiarized. Admittedly, one may not require assistance from the methods of hypothesis, to copy the description of an idea, as Newton did, by stealing it.

The quality of mental processes by means of which this progress occurs, from discovery of an ontological paradox to an experimentally proven discovery of a universal physical principle, is the typical form of mental processes which are collectively classed as *cognition*, as distinct from the imagined objects of sense-certainty. Vladimir Vernadsky justly adopted the term *noësis* as a designation for the act of discovery of a verifiable universal physical principle. The two terms, *cognition* and *noësis*, point toward the same object, the same process of mentation.

As the case of the efficient effect of the existence of objects of microphysics, illustrates the point most dramatically, objects which are visible to cognition, form a different class of the sub-microphysical objects than the objects defined merely by sense-certainty. These objects are termed *ideas*, in Plato's sense. This class of objects of knowledge, includes not only the universal physical principles of so-called physical science, but also those principles of Classical artistic composition which are discovered and verified in the same way.

This distinction is the central feature of the Socratic dialogues of Plato. There, willingness to accept the evidence that a given system of thought is paradoxical, is the precondition for the *truthfulness* of the proponent. Cognitive knowledge is truthful; when mere authority, or sense-certainty, or a combi-

nation of both, are upheld in defiance of the evidence that such opinion is ontologically paradoxical, the proponent is not truthful.

Thus, for example, the application of those principles leads us to define the entirety of scientific knowledge in the following way.

The notion of the universe, as defined experimentally in terms of human physical-economic activity, that as of the form of a Riemannian series of physical geometries, led me

---

---

*Rather than attempting to build up to the definition of cognitive phase-space from a succession of abiotic and living phase-spaces, I began always, as to the present day, from the starting-point of cognition as such.*

---

---

to divide the universe so defined among three general phase-spaces: *abiotic*, *life*, and *cognition*. The difference between my own and Vernadsky's views on this matter, is threefold.

First, I began from the standpoint of cognition, as a phase-space, to define the other two phase-spaces. Second, I adopted the notion of an anti-Euclidean series of Riemannian physical geometries, as my overview of these phase-spaces. Third, I located the individual cognitive processes' actions on the domains of abiotic and living processes, as mediated through the cognitive transmission of ideas into more general social practice, rather than as the individual's action directly on the abiotic and living domains. It is on this latter point, that my approach to defining the physical-economic function, differs from the role of cognition assigned to Vernadsky's definition of the *noösphere*.

The pivotal feature of my work to this effect, from 1948 on, was tracing the increase of the potential increase of the productive powers of labor, per capita and per square kilometer, from the social process by means of which an original discovery of universal principle generates those technologies which transform both the design of products and of the processes through which those products are generated.

This approach was prompted and conditioned, in turn, by my recurring studies in defense of Leibniz's monadology, against Kant's *Critiques*, which had become the center of my intellectual preoccupations since mid-adolescence. Thus, rather than attempting to build up to the definition of cognitive phase-space from a succession of abiotic and living phase-spaces, I began always, as to the present day, from the starting-point of cognition as such.

On what authority can we presume to define the systems

of abiotic and living processes, by starting from any other point of departure than the process by means of which we actually know the abiotic and living processes, the process of cognition?

The argument to be made on that account, is essentially the following. If, as Vernadsky sums up the modern history of this discovery, the action of living processes on the abiotic processes of Earth produces an effect in the latter which does not occur otherwise in abiotic processes, then an abiotic pro-

---

---

*The follies of most schools of philosophy, the sundry varieties of the reductionists, most notably, are rooted in the inability of sense-certainty to determine, in and of itself, whether the evidence of the individual's senses is either truthful, or an illusion.*

---

---

cess so under transformation by a living process, has been brought into existence within a geometry which differs axiomatically from the abiotic as such. A similar distinction was shown by me for the action of cognition on living processes. That being the case, were it not awful stubbornness, or sheer lack of even the most elementary scientific competence, to propose to derive the possible existence of living and cognitive processes from within the axiomatic phase-space domain specific to only the abiotic? Only by choosing cognition as the axiomatic basis, could a competent assessment be made of both the principles of development of the abiotic and living domain, respectively and collectively.

To restate and summarize the implication of that argument, as I have emphasized this in earlier locations. That approach implies that the Riemannian universe is composed of three principal phase-spaces: abiotic, life, and cognition. None of the latter two is implied in a predecessor, rather, the primary, axiomatic order, is the action of life, as a principle, upon the abiotic, and cognition on both the abiotic and living processes. Nothing in the universe exists outside, or independently of these three combined, except as it is created by what may be described as the combined action of those multiply-connected three Riemannian phase-spaces.<sup>22</sup>

*The follies of most schools of philosophy, the sundry varieties of the reductionists, most notably, are rooted in the inability of sense-certainty to determine, in and of itself, whether the evidence of the individual's senses is either truth-*

---

22. This has further and deeper implications, including theological ones, which were appropriately stated and reviewed in other locations.

*ful, or an illusion.* The most efficient, conclusive answer to that question, is obtained by tracing out the causes of what is, in fact, a dangerous, currently widespread form of mental illness: belief in "free trade."

Therefore, at this point, we shall hold the needed further discussion of the issue of sense-certainty versus knowledge in abeyance, until the next section of this report, when we will have considered the effects of the mental illness called "free trade" upon the long-term health of the nation's physical economy. At that point, the practical significance of relying upon my use of Riemannian physical geometry, for forecasting long-range effects in economic processes, will be more readily understood.

---

## 2. The Cult Of 'Free Trade'

---

The timeliness of this present report, is underscored by the inevitability of the accelerating collapse of the world's present, post-August 1971, floating-exchange-rate form of monetary-financial system. The third and fourth quarters of calendar year 2001 are virtually doomsday for this monetary-financial system. Remnants of that system might limp along for a bit longer, like a smoking wreck of an automobile which has burned out its engine's crankshaft; but, it could not be saved in its present form, even by such extreme measures as imposing a national and even global political dictatorship by the terminally decadent, present English-speaking powers.

The physical structure of the present U.S. economy, for example, is in vastly worse degree of relative disrepair than the U.S. found itself during 1929-1933. Only a sweeping and sudden reversal of the policy-changes introduced under the succession of the first Harold Wilson government of the United Kingdom and the U.S. Nixon and Carter Administrations, could prevent a collapse of an economy clinging to the terribly mistaken assumptions of Year 2000 Presidential candidates Bush and Gore. As a matter of practicable politics, only a sudden return to the policy-axioms of the Franklin Roosevelt Presidency, could prevent the U.S. economy itself from being carried to the inevitable doom which looms immediately ahead for the present world monetary-financial system.

Under these special circumstances of crisis, what I have to report here, has extraordinary importance for anyone intending to rescue this economy from that presently onrushing monetary-financial catastrophe.

As my own original discoveries of universal physical-economic principle emerged during the 1948-1952 interval, I was impelled more and more to translate the implied results of my discoveries of principle from an academic, into a practical form, a form comparable to an input-output analysis of national product and national income. Once I had adopted a Riemannian view of the implications of my discoveries, I recognized a potentially fatal fallacy in the way generally

accepted accounting practice affected the policy-shaping practice and performance of both private enterprises and U.S. national-income and product accounting. It was from this standpoint, beginning 1948-49, that I focussed attention on the fallacies inhering in the expression of the linear systems analysis which permeated what was also known then as Operations Research.

From those studies, even before my forecasts of the 1966-2001 interval, as early as 1959-60, it was already clear to me, that if generally accepted financial accounting, and related cost-accounting practice, were misinterpreted as suitable for use as instruments of shaping economic policy of firms and governments, that the results must be ultimately failures, even disastrous ones. The premises on which this conclusion must be reached, are essentially those which I have identified above. In this second, concluding section of my present report, I show, in a general way, how such misuse of financial and related forms of accounting practice have contributed greatly, and, as my forecasts have demonstrated, predictably, to the presently onrushing ruin of the U.S. and world economies.

The included result of the use of financial and related forms of accounting practice as an official, and also popular ideology, is expressed in its most pathological, extreme form, as the contemporary form of the U.S. cult of "free trade." It was the combined effect of the Mont Pelerin Society's global political influence and activities, with help of such novelties as the "supply side" cult and the Kemp-Roth legislation derived from it, which have led the once powerful and growing U.S. economy into the wreckage it represents today.

## Two Elementary Fallacies

I focus on two aspects of the effects of that misuse of financial accounting and its characteristic ideology. The first, generally underlying fallacy of financial accounting, it that it assumes, mistakenly, that a margin of gain, of financial income over monetary expenditures, is that factor of growth, profit, which defines a healthy enterprise. The second, related fallacy, is the wildly false assumption, that the national income of an economy should be measured as the sum-total of so-called "Value Added" of the nation's individual enterprises.

For example. In the courses on introduction to economics, which I taught at sundry campus and other locations, during the 1966-1973 interval, students expressing a doctrinaire socialist persuasion, would sometimes audit one or two of the thirteen two-hour lectures of that series. Thus, fairly often, during one of the periods of discussion which followed each lecture, I would be challenged by some student, often with a fanatical glint in his eye and voice, who, like a self-appointed spy for the Inquisition, would seek to catch me out as an exposed heretic to the dogma of his current persuasion.

Frequently, such young doctrinaire socialists, especially from among those of avowed libertarian or anarcho-syndical-

ist inclinations, would insist that "wealth is created 'by the horny hand of labor' at the point of production." This, many among these young people of 1966-1973 university campus days, defended, rather fanatically, as what would be fairly considered a corollary of "the labor theory of value." They were both gratified and humiliated by my response to their challenge: gratified that I had exposed myself as a true heretic to their dogma; humiliated by the simple clarity of the evidence which proved their dogma to be an "ivory tower" variety of absurdity. After one or two sessions, they never returned.<sup>23</sup>

Except for the worst variety of classroom "ivory tower" sophists, it is obvious, that if we hold the technology, and other internal features of an enterprise, constant, the principal cause of fluctuations in productivity within that enterprise, and in its impact on the economy as a whole, will be variations, more or less great, induced by the quality of development of the basic economic infrastructure within which the enterprise is situated.

It is also a simple matter of fact, that it is advances in applied technology brought into the enterprise, both respecting design of products and organization of the productive process itself, which largely determine the variability of relative productivity of the labor-force and facilities employed within the operations of that enterprise.

Also, the quality of education supplied both sectors of, and the entirety of the population's households, is a leading determinant of the productive powers of labor within the individual enterprise. The changes in demographic characteristics of the general population, or also even large sections of it, also have a powerful impact on the attainable levels of both average national productivity, and that within particular enterprises.

Furthermore, looking at the process of development of entire economies, we must confront the significance of changes in the composition of employment of the totality of the potential labor-force, and also changing demographic characteristics of both the population as a whole, and of particular strata within it, as of crucial bearing on the determination of relative physical productivity per capita and per square kilometer. For example, the greater the ration of skilled machine-tool and kindred specialists, of the ration employed in pedagogical and research experimentation, and the relative emphasis upon levels of technology and skill for which work-

---

23. These poor fellows did not realize that my being expert in knowledge of what Karl Marx's four-volume *Capital* and relevant other writings represented, meant that my knowledge on that and other matters of economics were my own, with no obligation to submit to Marx's doctrinal authority when I knew him to be mistaken, or knew Marx to have been a dupe of Urquhart or other controllers of the Young Europe network. Nothing would shock them more, than my response to their finger-stabbing at an English translation of some part of Marx's writings, "On that point, Marx was wrong." *Lèse majesté!* Their only resort was to either rage, or that inverted form of rage called depression.

places are designed, determine the relative productivity in the society as a whole, and thus contribute more to determine the productivity in the particular enterprise than any factor purely internal to either its organization, or the contemplations of the financial accountants and guardians of its merely momentary “shareholder value.” Notably, a population with a lower life-expectancy, can not attain, or maintain the productivity, or standard of living comparable to that formerly characteristic of the U.S.A. or western continental Europe.

Anyone who now reflects upon what I have emphasized in the preceding section, will recognize that I am defining the economy as a whole as a *system*, rather than a collection of individual enterprises. The current notion of an alleged principle of “shareholder value,” is not only directly contrary to the Preamble of the Federal Constitution and other expressed intent of that Constitution and Declaration of Independence; it is frankly insane in its inevitable consequences for national practice. I mean a *system* in the sense of a Riemannian physical geometry, as I have summarily identified the most relevant points in this report so far.

In sorting out the conceptual problems this might appear to pose, we must apply to the individual enterprise the Leibniz-Riemannian notion of relationship between an (ontological, monadic) *existence* and its immediate *position* in the system as a whole. We must thus take into account, the effect, on the economy, of the function of its existence per se, and also the effect of its functional location within the national division of labor as a whole.

For example, an *existent* class of enterprise, such as a closely held entrepreneurship supplying advanced technology to other, larger enterprises, may, by its current position within that economy, prevent a technological bottleneck which would otherwise be destructive of the potential progress of the economy more generally.

As I have stressed, to understand any system, one must approach the investigation from the standpoint of its evolutionary development, its evolutionary-revolutionary transformations in characteristic features. In studying society, in which the human cognitive will is its crucial distinction from abiotic and other living species, what we rightly distinguish as the *history* of the relevant development of society, provides the method and materials of the investigation.

Today, most popular opinion, included the so-called educated varieties, are expressions of minds trapped within a Flatland of psychedelic fantasies. These victims have lost a real sense of history, during a present time when society feels the effect, more and more, of a situation in which even children in primary and secondary schools, are being drilled more or less daily into allying politically with the school’s Orwellian “Big Brother”: the controlling social workers and their like, against the pupil’s own parents.

Sometimes, these days, one might think that even the Nazi youth organizations were less brainwashed than what has been done to the victims, the pupils, in schools directed by

the “Baby Boomer” generation representatives of the asocial tradition of such perverts as Theodor Adorno, Hannah Arendt, and systems analysis. More and more, the pupils so brainwashed into cultural pessimism, consider their own parents, and grandparents, and, more and more, even themselves, “an historical mistake,” as apparently, so does avowed “population freak” and former Vice-President Al Gore.

Among the most pathetic of the fanatically ahistorical, systemic delusions popularized in that way, has been the Mont Pelerin Society’s utopian image of a “free trade” society. Such is the wicked fairy-tale world, which has gained relative political hegemony since Richard Nixon’s 1966-1968 alliance with Ku Klux Klanners, Nashville Agrarians, and like types, in his “Southern Strategy” campaign for the 1968 Presidential election. To expose the form of the delusion of “free trade” rampant in the U.S. today, we must point the finger to the actual origins of the crucial systemic difference between the preceding form of European society, feudalism, and the emergence of modern society, in the form of the sovereign nation-state, beginning the Fifteenth-Century Renaissance.

## History And Economy

From approximately the time of the Roman murder of Archimedes, Rome rose rapidly to an hegemonic position in the Mediterranean and its adjoining areas. Its influence superseded that of that superior, Hellenistic culture, which had dominated the eastern Mediterranean since the succession of Classical Greece and the victory of Alexander the Great over the Achaemenid form of the Mesopotamian imperial tradition.

From the self-inflicted moral decay, and decline and fall of the Roman Empire, its power was passed on, by way of changes made by the Roman Emperor Diocletian, soon resulting in the establishing of Byzantium as imperial successor to Rome. As Byzantium itself rotted away under the influence of the Code which Diocletian bequeathed to it, Venice emerged, more than a thousand years ago, to become Constantinople’s de facto successor. Venice’s hegemony was that of a rentier-financier-based form of imperial maritime power. As the imperial power of Venice waned, during the latter half of the Seventeenth Century, the Netherlands and the British monarchy not only represented the kind of imperial rentier-financier maritime power Venice had formerly commanded; they were developed for this inherited role, under the explicitly Venetian influence expressed as the Eighteenth Century, anti-Classical Enlightenment.

During the entire sweep from approximately 212 B.C., until the Fifteenth Century, extended European civilization was dominated by the triumphant cultural characteristics of ancient Rome, or by the adjusted, Byzantine and Venetian versions of that Roman heritage known as the Code of Diocletian. There were some marginal exceptions, such as the efforts of Charlemagne, the Emperors Friedrich Barbarossa and Frederick II, Alfonso Sabio, and Dante Alighieri, to introduce





Venice's hegemony was that of a rentier-financier-based form of imperial maritime power—a role later assumed by the British monarchy, under the explicitly Venetian influence expressed as the Eighteenth-Century, anti-Classical Enlightenment. Here: St. Mark's Cathedral in Venice, and a 1785 engraving of Venetian operatives on the prow.

principles of statecraft and law which anticipated the refined goals set forth by the Fifteenth Century, pioneering forms of the modern nation-state, in Louis XI's France, and Henry VII's England. Until the Fifteenth Century, all such nation-building efforts were interrupted, and crushed by the power of the combination of ruling Romantic oligarchies.<sup>24</sup>

Against that long wave of history, even a relatively modest amount of accurate knowledge of key features of the change from feudalism to the modern nation-state, would suffice to show that the currently popular fads of "free trade" are not only lunatic fantasies, but constitute a systemic threat to the continued existence of civilization on this planet.

For example, consider the mid-1990s alliance, of those determined to uproot the Constitutional principle of the general welfare. This was the alliance between Republican Speaker of the House of Representatives Newt Gingrich and his crony of the late 1970s, Vice-President Al Gore, echoing the original, 1790s, Malthusian action, overturning the English poor laws, by the government of Britain's Prime Minister William Pitt the Younger. For that purpose, Pitt's government had employed the foolish propaganda of Thomas

24. "Romantic" signifies the tradition and culture of ancient Rome and its empire. It is used in no different sense and connotations than that, in all of my writings. For example, the Code Napoléon is an example of Romanticism, as the figure of the Consul and Emperor Napoleon Bonaparte is the first fascist tyranny in the history of modern Europe; all forms of fascism since them, including those of Benito Mussolini and Adolf Hitler, were explicitly predicated of the model provided by self-anointed Caesar and Pontifex Maximus, the modern imperial globalizer Napoleon Bonaparte.

Malthus, who wrote his notorious *On Population*,<sup>25</sup> parodying the English translation of Giammaria Ortes' treatise on population-control.<sup>26</sup> The same kind of "Malthusian" policy to which Al Gore had been won, had been argued by Giovanni Botero, a Sixteenth-Century contemporary of Paolo Sarpi.<sup>27</sup> The foolish Malthus's parody of Ortes, later found expression in the opinions of the notorious Charles Darwin.

However, what is often called the Malthusian doctrine of today, was already implicit in the Code of Diocletian, and thus, implicitly, the policy of Roman and feudal society. It was this doctrine, as embodied in that Code, which guided Byzantium to that long wave of collapse of its population levels. As George Gemistos, also known as Plethon, writing at the onset of the Fifteenth Century, warned the Byzantine emperor, these doctrines must be abandoned, if exhausted Constantinople were to survive the onrushing Ottoman conquest. They were not reversed, and Constantinople fell.

The pro-genocidal population policies of Botero, Ortes, Malthus, today's Darwinists, and other neo-Malthusians, are not peculiar to modern society. They were already deeply embedded policies of doctrine and practice in both ancient and feudal society. It was not until the Fifteenth-Century,

25. London: 1798.

26. *Reflections On The Population Of Nations In Respect To National Economy* (Venice: 1790). This work of Ortes, not the Malthus parody, was the document upon which the UNO Cairo Population Conference draft was based.

27. *Della ragione di stato*, 1588 (English trans., 1606).

Italy-centered Renaissance, that the axiomatic basis for such policies was overturned with significant, if partial success, as an integral feature of the initial establishment of the modern, sovereign form of nation-state.

I have said the following, repeatedly, on earlier occasions, but it must be emphasized again here. Prior to the Fifteenth-Century Renaissance, the prevalent doctrine of practice of virtually all society, was to relegate the great majority of the total population to the functional status of virtual human

---

---

*The Renaissance's introduction of the principle of the general welfare as natural law, represents a dividing-line between ancient and feudal society, on the one hand, and the emergence of the modern sovereign nation-state republic, such as the model later provided by the U.S. Constitutional republic, on the opposing side.*

---

---

cattle, such as serfs, slaves, or the subject populations of imperial colonies or satrapies, or to a condition expressed by the present-day victims of Orwellian "Big Brother" mass-brainwashing by the leading mass media. The Renaissance's introduction of the principle of the general welfare *as natural law*, represents a dividing-line between ancient and feudal society, on the one hand, and the emergence of the modern sovereign nation-state republic, such as the model later provided by the U.S. Constitutional republic, on the opposing side.

The ancient Roman, Byzantine, and feudal forerunners of Malthusian population control, expressed, thus, the same alleged principle which the notorious Dr. François Quesnay presented as the crucial axiom of his Physiocratic dogma. I mean that same so-called principle of *laissez-faire*, which Adam Smith plagiarized from the Physiocrats as "free trade."

There are two crucial assumptions of relevance underlying that doctrine called variously *laissez-faire* or "free trade."

In the first instance, Quesnay's sophistry is, as Marx's description of Quesnay's *Tableau Économique* argues, that the "surplus value" of the feudal estate, is the fruit of the aristocratic landlord's possession of the title to that estate. Quesnay's corollary argument is, that the contribution of the peasants to the production of the output of farming or mining, is no more than the landlord would have to pay as the bare cost of sustenance for those virtual human cattle classed as serfs or the like. Therefore, according to Quesnay, the gains in physical output by society are the natural property of the

titled land-owners; and, those who actually produce wealth are deemed entitled to no more than a bare subsistence, until such time as they are deemed ripe to be culled, when aged, sick, or deemed too numerous for the landlord's convenience, as cattle are. The relationship of such perverted opinions to the influence of John Locke and the doctrines of "shareholder value," should be obvious.

The precedent for this curiously nasty sophistry by Quesnay, is to be found in the medieval history of France, as in locations along the Garonne, Tarn, and Rhône, or amid the Pyrenees. That precedent is, the neo-Manichean doctrine of those Cathars otherwise known as the *Bogomils*. In that cult, the "elect" are rewarded by their god, whatever that thing might be, with benefits which they accrue for no other reason than their status as members of the "elect." We meet the same sophistry in the theology of the notorious U.S. figure of Aaron Burr's grandfather, Jonathan Edwards, an occult pagan belief in which the more lunatic varieties of U.S. gnostic cults participate still today.<sup>28</sup>

The same Physiocratic doctrine of those Bogomils, who are sometimes referred to as "buggers" in the English language,<sup>29</sup> appears as the doctrine of "Property" of England's John Locke, and the notorious pro-satanic Bernard Mandeville.<sup>30</sup> It is, presently, a pervasive feature of the lingering ideology of Richard Nixon's "Southern Strategy" doctrine; it is expressed by the presently dominant trends toward the pro-Confederacy, neo-Lockean dogma of "shareholder value," in the misshaping of adopted U.S. economic policy of practice during the recent thirty-odd years.

The modern effort to attribute some sort of rational cover for that wild sort of arbitrary pagan superstition, can be traced in modern English history from the writings of Galileo's student Thomas Hobbes. The argument to that effect by Mandeville and his followers, such as former Vice-President Al Gore, is, that even billions of daily, apparently random, free-will decisions among the members of society, will tend, in combined effect, to produce benefits for mankind, by agencies which are beyond the powers of mankind to comprehend the workings of such a marvelously secret agency working from under the floorboards of reality.

Precisely that wild-eyed sort of superstitious "algorithm," was virtually shouted by Gore, in his hate-filled vituperations against his host of the moment, the Prime Minister of Malay-

---

28. Cf. Stanley Ezrol, "Seduced from Victory: How the Lost Corpse Subverts the American Intellectual Tradition," *EIR*, Aug. 3, 2001.

29. Traditional English slang for the Slavic term "*Bogomil*," was "bugger."

30. Mandeville was adopted by the late Friedrich von Hayek as the nominal patron anti-saint of his Mont Pelerin Society cult. Mandeville's dogma correlates exactly with the argument used by the followers of Adam Smith and the British East India Company's Haileybury School generally. It is, consequently, the religious doctrine preached by the U.S. Heritage Foundation and associated cult-formations, a doctrine which forms the basis for the currently reigning legal aberration known as "shareholder value."

sia.<sup>31</sup> In the realm of statistical theories, that means that that imaginary thing, the god of the Bogomils, is running the universe as a crooked gambling house; it means that such doctrines are not economic matters arguable among rational beings, but an intrinsically unarguable sort of gnostic mystery religion, for which no rational defense ever will, or could be presented.

In the case of Adam Smith, the same sort of pagan mystery religion dominated the views he expressed even prior to his departure to France, that under the patronage and instruction of the British East India Company's notorious Lord Shelburne. Exemplary is a passage which the departed David P. Goldman and I quoted from Smith's 1759 *Theory of the Moral Sentiments*.

“... Nature has directed us to the greater part of these [desires] by original and immediate instincts. Hunger, thirst, the passion which unites the two sexes, the love of pleasure, and the dread of pain, prompt us to apply those means for their own sakes, and *without any consideration of their tendency to those beneficent ends which the great Director of nature intended to produce by them.*”<sup>32</sup>

The notable, functional difference between the otherwise parallel sophistries of Quesnay and Smith, is that the variant proffered by Locke, Mandeville, and Smith, expresses the social characteristics of a Venice-style rentier-financier class's imperial maritime power; whereas, Quesnay leans quixotically to the inclinations of the Seventeenth Century's Anglo-Norman-French, pro-feudalist, *Fronde* tradition. Locke, Mandeville, and Smith, like William of Orange and Lord Shelburne, reflect the Venice-styled rentier-financier interest of those Dutch and British India Companies which employed such creatures as David Hume, Smith, Jeremy Bentham, Thomas Malthus, and the rest of the Eighteenth and Nineteenth Centuries' Haileybury economists. The distinction is that between the feudal landlord and the lords of the Venice-style Anglo-Dutch financier aristocracy.

There is no difference, however, in the preference of both types for the tradition of oligarchical models of society, in which a relatively small class of oligarchs, flanked by their

---

31. In his vituperation against Malaysian Prime Minister Dr. Mahathir bin Mohamad, at the APEC summit in Kuala Lumpur, Malaysia on Nov. 16, 1998, Gore proclaimed, “Today's economy operates on the information standard. A nation's economic power comes from votes of confidence cast constantly in markets around the world that evaluate every government's policies every day, through billions of transactions.” The wonderful irony of that incident, is that Al Gore's outburst of bi-polar rage, on that occasion, was Al's implicit defense of predatory financial speculator George Soros, who practices precisely the same evil which Gore preaches.

32. Lyndon H. LaRouche, Jr. and David P. Goldman, *The Ugly Truth About Milton Friedman* (New York: The New Benjamin Franklin House, 1980), p. 107. Italics added.

retinues of lackeys, reign over, herd, breed, and cull the relevant inventory of persons degraded from human status, to that of human cattle. Such is the evil superstition inhering in today's rentier-financier notion of “shareholder-value society.”

## Modern Political Economy

The economic significance of the history which I have just summarized, is illustrated, rather well, by contemporary standard studies of the curve of population and of crucial demographic characteristics of those populations. The Fifteenth-Century, Italy-pivoted Renaissance, represents a qualitative improvement in the condition and future prospects of mankind, a quality of improvement without precedent in both earlier history and prehistoric human existence (**Figure 3**).

Therefore, it would be insanely reckless, to attempt to analyze post-Fourteenth Century, modern European history and its physical-economic development, except from the standpoint of identifying those new institutions and relationships which define the post-feudal form of modern sovereign nation-state, a form of nation which did not exist prior to the Fifteenth-Century Renaissance. In this perspective, the practice of the ideology of “free trade,” especially when “free trade” is combined with “globalization,” is shown to be a throw-back to that form of Venetian imperial rentier-financier power, usurious practices, and consequences, which plunged Europe into what historians call “The New Dark Age” of the Fourteenth Century.<sup>33</sup>

The struggle of Europe to free itself from the imperial legacies of ancient Rome and the Code of Diocletian, since St. Augustine and his followers generally, and since Alcuin and Charlemagne, Abelard of Paris, Alfonso Sabio, the Hohenstaufen emperors, and Dante Alighieri, was summarized in the work of the single greatest intellect of both the Fifteenth and Sixteenth Centuries, Cardinal Nicholas of Cusa.

Cusa, whose 600th birthday we celebrate this year, was the intellectual founder of the modern nation-state, and the founder of modern globally extended European experimental science. Merely exemplary of his contributions to all modern, and earlier civilization, are his *Concordantia Catholica* (the principle of a community of principle among modern sovereign nation-states), his ecumenical dialogue *De Pace Fidei*, and his initial treatise founding modern science, *De Docta Ignorantia*.

Such emphatically self-declared followers of Cusa as Luca Pacioli, Leonardo da Vinci, and Johannes Kepler, have attested to this. So does Cusa's leading position in organizing the campaign for those transoceanic missions which, among other things, led Christopher Columbus to rediscover the con-

---

33. In that sense, Barbara Tuchman's *The Distant Mirror: The Calamitous Fourteenth Century* (New York: Alfred A. Knopf, 1978) has a certain prophetic quality for today's world.

FIGURE 3

**Growth Of European Population, Population-Density, And Life-Expectancy At Birth, Estimated For 100,000 B.C.–A.D. 1975**

*Alone among all other species, man's numerical increase is a function of increasing mastery over nature—increase of potential population-density—as reflected historically in the increase of actual population-density. In transforming his conditions of existence, man transforms himself. The transformation of the species itself is reflected in the increase of estimated life-expectancy over mankind's historical span. Such changes are primarily located in, and have accelerated over, the last six-hundred years of man's multi-thousand-year existence. Institutionalization of the conception of man as the living image of God the Creator during the Golden Renaissance, through the Renaissance creation of the sovereign nation-state, is the conceptual origin of the latter expansion of the potential which uniquely makes man what he is.*

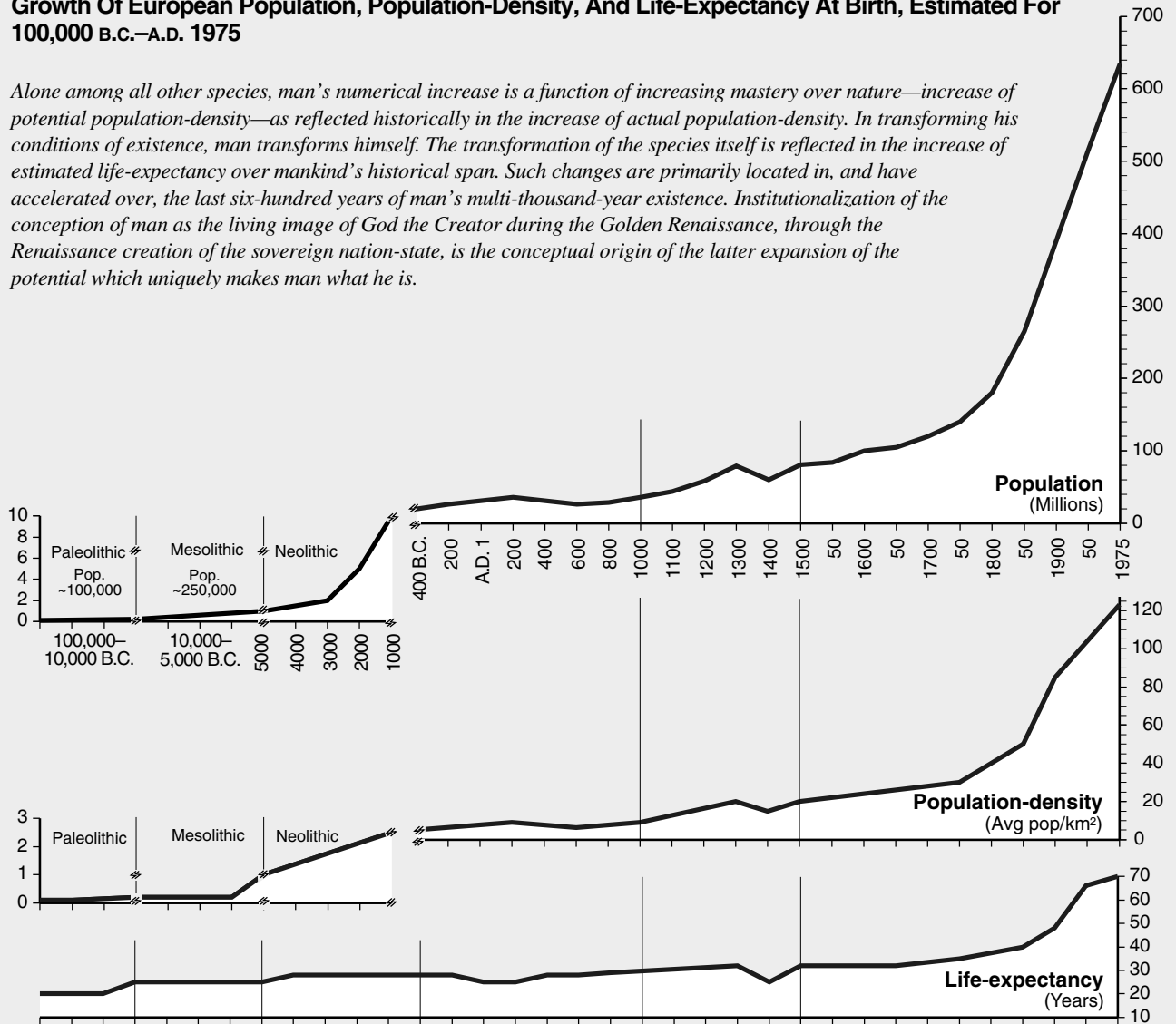

All charts are based on standard estimates compiled by existing schools of demography. None claim any more precision than the indicative; however, the scaling flattens out what might otherwise be locally, or even temporally, significant variation, reducing all thereby to the set of changes which is significant, independent of the quality of estimates and scaling of the graphs. Sources: For population and population-density, Colin McEvedy and Richard Jones, *Atlas of World Population History*; for life-expectancy, various studies in historical demography.

Note breaks and changes in scales.

continent across the Atlantic.<sup>34</sup>

The principle of the sovereign nation-state republic, as typified by the expressed intent of the principal founders of the U.S. constitutional republic, as intended by such as En-

gland's Sir Thomas More earlier, is the dividing-line, which separates modern civilization from the relative bestiality of virtually all ancient and medieval history.

As to the history of the emergence of the modern sover-

34. From *Ibykus*, No. 38, 1992: Paolo Vitali, "Die Entdeckung der Neuen Welt: Das Kolumbusprojekt"; Paolo Emilio Taviani, "Italienische Renaissance und die Entdeckung der Neuen Welt: Toscanelli und Kolumbus"; Morales Padrón, "Die Leistung des Christoph Kolumbus"; Pablo Castañeda, "Vasco de Quiroga und die Evangelisierung Lateinamerikas." From *Fidelio*,

Vol. 1, No. 2, Spring 1992: Helga Zepp-LaRouche, "Columbus And The Christian Concept Of Man"; Nora Hamerman, "The Council Of Florence: The Religious Event That Shaped An Era Of Discovery"; Ricardo Olvera, "Columbus And Toscanelli"; Salvador Lozano, "The Battle Against Ptolemy's Geography"; Richard Sanders, "The Science Behind Columbus"; Tim-

eign nation-state, the essentials of the matter are summarized, chiefly, in three sources. Professor Friedrich Freiherr von der Heydte's *Die Geburtsstunde des souveränen Staates*,<sup>35</sup> my own numerous writings on this subject, and the review, delivered as her recent Bad Schwalbach address, by Helga Zepp-LaRouche, of von der Heydte's thesis from the standpoint of such later developments of the Fifteenth Century as the crucial role of Cusa.<sup>36</sup> The points of economic relevance to be stressed here, are the following.

The new form of society, the modern sovereign nation-state, has four outstanding features which distinguish it, as a system, from all predecessor and opposing forms of society. These four features define that form of society as a system, a system which is axiomatically distinct in its characteristic features from all other forms of society. It is the violation of those characteristics, most notably by the trends of the recent thirty-odd years, which has defined the U.S. and relevant international monetary-financial systems as the self-doomed system now gripped by its terminal collapse-phase.

*The first characteristic feature of the sovereign nation-state republic, or community of principle among such nations, is that it outlaws the attempts of oligarchies to hold human beings in the status of virtual human cattle.*<sup>37</sup> The first law of the modern form of sovereign nation-state, is that no government has the moral authority to govern, except as it is efficiently dedicated to promote the general welfare (the common good) of all of the people and their posterity. This is a principle of natural law, from which all legitimate constitutions and other law must turn, to prove and define their authority as law.

The state is not only obliged to adhere to this law in respect to its internal affairs, but also in its relations with other nations and peoples. It must promote the common good among nations and peoples, while defending the principle of perfect national sovereignty as an essential means for meeting the general obligation to the common good of humanity as a whole.

*Second, it obliges the state to develop and maintain those forms of basic economic infrastructure on which the defense and improvement of the general welfare depend.*

---

othy Rush, "Prince Henry's Navigations"; Carlos Cota Meza, "Who Really Killed Off The Aztecs?"

35. Regensburg: Druck und Verlag Josef Habel, 1952.

36. Helga Zepp-LaRouche, "Honoring Nicolaus of Cusa: A Dialogue Of Cultures," *EIR*, July 6, 2001.

37. Despite that satanic abomination known as the Southern slaveholders' system, President Abraham Lincoln's determination, unlike the disgusting U.S. Democratic Party of Presidential candidate McClellan, to purge this treasonous pack of moral degenerates from a controlling position in our republic and its economy, was truly a defense of the original intent of the principal authors of the 1776 Declaration of Independence and 1789 Federal Constitution. As a matter of the intent of U.S. constitutional law, slaveholding was always an intrinsically treasonous abomination against both God and mankind.

The state may delegate such duties to non-governmental agencies, but the state may not lawfully relegate the authority in the matter to such agencies, and must hold those assigned agencies accountable for their fulfillment of their designated responsibilities on this account. This means such infrastructure as is needed to promote relevant improvements in the entirety of the area which the nation represents, and for the maintenance and improvement of the demographic characteristics and cognitive development of the entire population.

*Third, the sovereign nation-state can not relinquish its unique sovereign monopoly of authority for creating and regulating its currency and public credit.* This removes such monopolies and authorities from the hands of an active or incipient rentier-financier class.

*Fourth, the state must promote the increase of the productive powers of labor through emphasis upon the benefits of scientific and technological progress, and the promotion of those forms of the arts which are essential for the promotion of those qualities of the individual human mind, and human cognitive relations, upon which the continuation of the benefits of scientific and technological progress depends.*

These four principled features of the modern sovereign nation-state republic's constitutional composition, define an elementary conflict between competent forms of economic management, and today's generally accepted methods of financial accounting, and today's derivatives of the latter methods.

I now develop the implications of what has just been summarized, as follows.

## Private Enterprise

The proper role of private enterprise in agriculture and manufacturing, and kindred undertakings, is located chiefly within the fourth of the just-stated categories of the nation's economic functions. Our focus upon that topic at this point in the report, returns our attention to the issues of cognition addressed within the preceding chapter.

The fact that cognition represents the third, and highest ranking of three principled forms of universal phase-space, is a modern discovery. Nonetheless, that fact was always a pre-existing, functional principle, doing its work, even while awaiting its belated discovery; it has functioned as a universal physical principle, whether it were consciously acknowledged, or not. Even without discovery of that principle, the efficiency of that principle was already reflected in the known evidence of certain crucial effects.

Already, since no later than the dialogues of Plato, there existed the notion of cognition, and of the ideas of principle it generates, and, also, a related conception which is sometimes called "the idea of progress," the idea of the possibility of choosing constant, willful change for the betterment of mankind's condition.

Among the crucial features of the process leading into the



FIGURE 4  
The Catenary

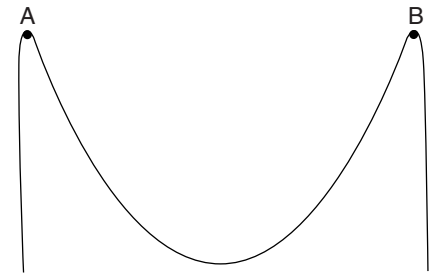

*Filippo Brunelleschi (left) applied the physical principle of the catenary to solve what had been estimated as the impossible task of putting the required cupola on the Florence cathedral of Santa Maria del Fiore. The surfaces between the ribs of the dome are families of catenaries.*

launching of what became the Fifteenth-Century Renaissance, as in the university in Padua at the close of the Fourteenth Century, was the role of what are called, in modern times, *Classical humanist modes of education*. Exemplary are the role of the Brothers of the Common Life, and the education of Cusa himself. Filippo Brunelleschi, who applied the physical principle of the catenary to solve what had been estimated as the impossible task of putting the required cupola on the Florence cathedral of Santa Maria del Fiore, typified that florescence of the creative scientific and artistic spirit which characterized the intellectual process of much more than a century (Figure 4). This is a process of preparation and realization which leads from the work of such as Dante Alighieri, Petrarch, and the Brothers of the Common Life. Cusa's founding of modern experimental physical science typifies this, as does Leonardo da Vinci, whose work bridges the span of the late Fifteenth to early Sixteenth Centuries. The outcome of these predecessors' work, as seen in the towering genius of Kepler, typifies this.

Throughout all now globally extended influences of European civilization, from Egypt, Pythagoras, Solon, and Plato, to the present time, globally extended modern European civilization has been underlain, and thus dominated by a continuing struggle for absolute supremacy between two principal, opposing, leading intellectual forces, the one most conveniently named *Classical*, and the other typified by the past 2,300 years of the opposing, Romantic, current. I now illustrate that point.

I resort again to music as an example. Contrast the Classical current of musical composition, that of J.S. Bach, Haydn, Mozart, Beethoven, Schubert, Brahms, et al., to the Romantic faction of Rameau, Fux, Liszt, Wagner, et al.

The *non-deductive* method of Bach, rooted in a well-tem-

pered contrapuntal polyphony situated within a geometry defined by the principle of Florentine *bel canto* voice-training, contains nothing arbitrary in its process of development of compositions as wholes. All is based upon the principles of cognitive solutions for contrapuntal musical paradoxes of consonance. It is the resolution of such paradoxes, as the use of a series of Lydian intervals by Mozart and Beethoven, for example, which defines these compositions as products of human cognitive reason.

In contrast, the Romantic school of Rameau and his admirers, relies upon arbitrary production of what they seek as "pleasing effects," often resulting in a type of composition which suggests the principle of extrusion one might expect from a purchase of Germany's famous curry sausage. Romantic formalist Fux, of *Gradus Ad Parnassum*, achieves irrationality in a different way, through imposing arbitrary definitions, axioms, and postulates.

In Classical poetry and drama, the artist relies entirely upon ironies, especially crucial metaphors, which oblige the mind of the audience to produce cognitive solutions for such paradoxical features of the composition. The Romantic, as typified by Venice-trained Hobbes and his followers, relies upon the unresolved irrationalities of symbolism, as a disgusting substitute for irony and metaphor.

These same classes of distinctions are characteristic of the conflict between Romantics, such as Galileo, Newton, Euler, Lagrange, Laplace, and Cauchy, in mathematical physics, and Classical scientific method, as typified by Plato, Kepler, Leibniz, Gauss, Riemann, et al.

The crucial point of difference in each of these and comparable cases, is the reliance upon, or exclusion of the method of cognitive discoveries of principled solutions for the kinds of paradoxes which are the reflection of that principle of meta-

phor which is central to Classical methods of artistic composition, in poetry, drama, music, painting, sculpture, and architecture alike.

As I have repeatedly shown, in earlier locations, the term “universal physical principles,” applies equally to the characteristic universal principles of, respectively, abiotic, life, and cognitive phase-spaces. As Vernadsky argued this much, a physical principle is one which is revealed experimentally by physical effects which occur only as a result of its implicit intention, that in the sense of Kepler’s use of the notion of *intention* as corresponding to the efficiency of universal physical principles. Thus, *inasmuch as Classical artistic principles enable society to achieve those increases in potential relative population-density of society which can be achieved in no other way, those artistic principles, and the notions of statecraft they imply, must be accepted as being universal physical principles in the same degree as universal physical principles of abiotic phase-space.*

The proper function of private entrepreneurship, is rooted in the fact, that the power to create and apply cognitive discoveries of universal physical principle, is unique to the internal cognitive processes of the individual human mind.

As I have detailed this in earlier locations, the processes by which the notion of an hypothesis, and its corresponding universal physical principle, are generated, are opaque to the senses of a would-be external observer. The ontological paradox which prompts the cognitive discovery, is composed of sensible effects; the appropriate experimental verification of a universal physical hypothesis, as a proven principle, is composed of sensible effects. The action which connects that paradox to that proven hypothesis, can not be observed directly by the senses of an external observer.

The communication of the action of cognition, from one sovereign individual mind, to another, can occur only through the process of replication of the same three-fold experience in both minds. The act of communication of all classes of cognitive notions, which is to say of the nature and implications of universal physical principles, can occur only in this way.

This includes the transmission, to the living, of knowledge of discoveries by persons long deceased. The principle of practice of a Classical humanist mode in education, is an example of this connection across many successive generations. There are two commonly practiced, mutually antagonistic methods of instruction: one called *learning*, the other called *cognition*. *Learning* is a matter of conditioned behavior; *knowledge* is the result of reenacting the *cognitive* experience of discovery of verified universal and related principles. The substitution of learning for knowledge, in educational policy, is among the cruelest, most destructive follies of the practice of recent generations. I have used the example of today’s student, in secondary education, re-experiencing of an original act of discovery of a universal principle by Archimedes, 2,300 years earlier, as an example of methods of trans-

mission of knowledge, rather than mere learning.

*The progress of the human species, its increased power in and over the universe in which it lives, is entirely the consequence of the historical accumulation of combined discovery and transmission of knowledge in the equivalent of a Classical humanist mode.* Here lies the key to the essential contribution which private enterprise, as an institution, proffers to the economy of the well-ordered sovereign nation-state.

The most relevant illustration of that point, is provided by examining the normal functional relationship between the inclusion of a fundamental research function in the university system, and the transmission of universal physical principles to designs of products and improved processes of production by the mediation of the same machine-tool-design function which is essential to design of universal proof-of-principle experiments. This form of organization of society, as a science-driver economy, is implicit in all successful practice of modern economy to date, and provides the model around which all reforms of modern economy ought now to be premised.

The model of a most desired type of private entrepreneur is essentially a technological innovator. He, or she, is a scientist, an engineer, a machine-tool-design specialist, a modern high-technology farmer, or of similar qualifications. Sometimes, his commitment to innovation is called “risk,” but the ordinary use of that term today is misleading. The most relevant form of “risk” in his or her endeavors, is the kind of intellectual risk expressed by society’s best original discoverers of scientific and related principles: the commitment to risk the expenditure of the best adult years of one’s life in making something work, to the implied benefit of mankind, which never worked before. It is that individual’s qualification for taking that risk, combined with the passion which will not let him shirk what that intention demands of him, which is the mark of the qualified individual entrepreneur, or a small group of entrepreneurial individuals in a kind of symbiotic partnership.

This sort of agricultural, industrial, and kindred entrepreneurship and profession, is the active surface where progress is expressed to the benefit of the society within that surface. The other three principal components of the modern sovereign nation-state economy, 1.) The overriding commitment to promote the general welfare; 2.) The responsibility of the state for ensuring the development and maintenance of basic economic infrastructure; and, 3.) The monopoly of the state in the matter of the currency and supply of public credit, are the essential setting within which the essential role of the entrepreneur is situated. It is that arrangement among these four principal elements, which defines the viable form of modern nation-state economy.

## **The Public Corporation**

Generally speaking, the spread of the lunatic cult of “shareholder value,” has blinded current public opinion and



governmental policy-shaping, to the functional difference between a corporate entity consistent with what Treasury Secretary Alexander Hamilton and other patriots defined as the “American System of political-economy,” and the modern corporation controlled essentially by today’s combined power of modern rentier-financier interest and its attached major law firms.

With rare exceptions, the crushing of the former role of the closely-held small to medium-sized entrepreneurship, by the rise of the giant financial-market-controlled industrial or other corporation, has been a cruel setback for the cause of the general welfare. However, the problem this expresses today, always expressed a parasitical political aspect of our national economy, from a time before the 1776 Declaration of Independence. The nature, and possibility that we might cure that problem, demands that we summarize the leading features of that aspect of our national history here.

From the period of the accession of the British tyrant William of Orange, the English colonies in North America were divided into two antagonistic currents. The reports by Cotton Mather typify this.<sup>38</sup> By 1763, when the Benjamin Franklin-led steps toward American independence were set into motion, the factional division within the future republic was already well defined, as Anton Chaitkin’s *Treason In America* has documented the essentials of this history.<sup>39</sup>

Chaitkin, like Lowry defines the negative factional interest in U.S. political, economic, and cultural life, as what has been known, to the present day, as “The American Tory” faction. With the formation of the Democratic Party by the treasonous Aaron Burr’s successor, Martin van Buren, the treason faction in U.S. life has been centered in an alliance among the nation’s drug-trafficking partners of the British East India Company, the Manhattan-centered cabal of rentier-financier families, the Southern slaveholders, and such present-day continuations of the latter formation as the Nashville Agrarians.<sup>40</sup>

The patriotic faction, as organized by Benjamin Franklin, has been best typified by such Presidents as Washington, Monroe, John Quincy Adams, Lincoln, Garfield, McKinley, Franklin Roosevelt, and, briefly, Kennedy.<sup>41</sup>

---

38. H. Graham Lowry, *How The Nation Was Won: America’s Untold Story Vol. I: 1630-1754* (Washington, D.C.: Executive Intelligence Review, 1987), passim.

39. 2nd edition (New York: New Benjamin Franklin House, 1985).

40. Stanley Ezrol, op. cit.

41. The Presidency of Washington’s successor, John Adams, was spoiled by the treasonous influence of British diplomat-spy Sir John Robison, whose fraudulent book, *The Roots of the Conspiracy*, led to the adoption by Adams’ Administration of the folly of the Alien and Sedition laws. Ironically, it was the British Foreign Office of Jeremy Bentham et al., which had orchestrated the 1789-1794 Jacobin Terror in France, and set into motion the operations against the U.S.A. conducted under the Bonaparte dictatorship. At that time, the U.S. had two principal enemies, the British monarchy and the Chancellors, selected by the princes of the former Holy Roman Empire, who still

Consequently, as President Franklin Roosevelt emphasized, from the beginning of U.S. independence, the nation and its institutions were a continuing battlefield, on which an ultimately mortal conflict between the patriotic and American Tory factions has been fought. Since the successful 1901 assassination of President William McKinley by an agent conducted through New York City’s Henry Street Settlement House, the phenomenon of the Wall Street-centered, shareholder-owned public corporation, has become a creature controlled, top down, by the American Tory faction. Since the Presidencies of Grover Cleveland, Theodore Roosevelt, and Woodrow Wilson, and the campaign to establish the Federal Reserve System, the U.S. economy, and much of our Federal political institutions, have been controlled, most of the time, through the combination of financial houses of a rentier-financier character and their complements among the leading Establishment law firms of places such as New York and Washington, D.C.

This conflict is reflected in President Franklin Roosevelt’s open war against what he identified as the American Tory faction, and in the echo of that same war during the short-lived span of the Kennedy Administration.

Since World Wars I and II, the superior economic power of the U.S.A., has been reflected in the shifting character of an inherently problematic alliance between that U.S. “Establishment,” and the far-flung British monarchy. Since World War I, the conventional term for this “special relationship” has been the “BAC” or “British-American-Canadian” establishment, or what continental Europe’s political conventions identify as “the Atlanticists.”

Over the course of the Twentieth Century, especially after World War II, the increasing popularity of the U.S. alliance with Britain thinned the ranks of avowed American patriots. It was no longer considered patriotic, in the mass media and leading educational institutions, and other places, to emphasize publicly the long-standing adversarial relationship of the U.S. to that original and ancient enemy of our republic, the British monarchy. The patriotic current, continued to exist, if in relatively diminished numbers, but, now, it was expressed chiefly as what one-time Secretary of State Henry A. Kissinger has denounced publicly as “the American intellectual tradition” of Franklin Roosevelt, et al.<sup>42</sup>

---

controlled Austro-Hungary. Napoleon’s ambitions to be the new Caesar of a revived Roman Empire, rivalled, in more senses than one, the interests which subsequently established the Holy Alliance. The included result of Robison’s work as a British agent working against the U.S.A., was the successful penetration and disorientation of the Jefferson and Madison Administrations by British agent of influence Albert Gallatin. The organization of what became the American Whig Party, by Philadelphia’s Mathew Carey and others, rescued the nation from the ruin caused by the then-existing parties. Presidents Polk, Pierce, and Buchanan, were agents of the treasonous party, as were Grover Cleveland, Theodore Roosevelt, Woodrow Wilson, and Calvin Coolidge.

42. “Reflections on a Partnership: British and American Attitudes to Postwar Foreign Policy, Address in Commemoration of the Bicentenary of the Office

Therefore, in examining the role of such “shareholder interest” in the character and dynamic of the U.S. national economy, we must not be such credulous fools as to seek the problems of the public corporation in the form of that institution itself; rather, we must emphasize the way in which the American Tory faction of financier-rentier interest, represented by the combination of financial houses and their law firms, has taken over, and utilized the institution of the public corporation, and, often, much of our Federal government as well.

The systemic gutting of the economic ranks of the independent farmer, goods-producing entrepreneur, and science-trained professionals, reflects a long process of crushing the American entrepreneur, to the relative political and economic advantage of the rentier-financier-dominated public corporation. The savage turn against even the memory of Franklin Roosevelt immediately upon his death, echoing the attacks on him during the 1944 Presidential election-campaign, set the general post-war pattern. The assassination of President Kennedy and Warren Commission proceedings, set the stage for unleashing Nixon’s 1966-1968 “Southern Strategy,” a virtual counter-revolutionary coup against the U.S. Constitution. The devastating blows to the U.S. economy which were delivered after President Carter, such as the Garn-St Germain and Kemp-Roth legislation, were merely a continuation of the awful things done under Carter and Nixon earlier.

Now, here is how all that fits together to define the moral and economic degeneration of the public corporation, especially that which has occurred over the recent thirty-odd years. What should be the obvious fallacy of the popularized lunacy of the notion of shareholder interest today, is shown most simply by reminding the reader that *it is not objects as such which define a system, but, rather, the physical geometry within which those objects exist*. The awful damage which shareholder interest has done to the U.S. economy during the recent thirty-odd years, can be summed up in one word, “deregulation.”

I emphasize again, that it is not the corporate form as such, which is at fault; it is the evolution of the legal environment—*the geometry*—under which corporate behavior has collapsed to the level of moral and intellectual degeneracy exhibited by the present U.S. crisis.

The corporate form, in and of itself, is “morally neutral.” It is neutral because it is merely abstract, not real. Whether it is good or bad, is determined by the intentions, expressed as rules, rules which are imposed upon the actual corporation by society. This includes the rules set by the management, or the stockholders.

The most important kinds of rules pertaining to the performance of public corporations generally, are the rules set by

government, most notably our Federal government. These rules by government have two most significant expressions: statutes, and administrative discretion by the Executive branch. This combination of rules, is, in turn, most strongly influenced by relevant trends in public opinion. It is those rules which determine the controlling geometry in which the public stock corporation exists.

The appropriate general character of the principles which the rules ought to express, is that identified implicitly in the opening paragraphs of the 1776 Declaration of Independence

---

---

*The problem of today’s public stock corporation, is broadly defined as disregard for, or even hostility toward the implications of the principle known by the name of general welfare, or common good.*

---

---

and the 1789 Preamble of the Federal Constitution: the defense of the existence of the sovereign form of nation-state republic, combined with the principle, that no government has the moral authority to govern unless it is efficiently dedicated to the promotion of the general welfare of all of its population, all among their posterity, and all of the territory it represents.

In other words, no legislature should make, or tolerate any law which violates those two, interdependent principles. No court may nullify those principles in effect of its decisions. No charter for a corporation should be granted by any agency of government, which does not efficiently express the ruling authority of those principles, over the choice of intention of that entity, and over the standard of its performance in respect to those principles of the Preamble.

Such is the difference between a constitutional republic, and a nation which uses what is called “basic law” as a substitution for a constitution premised upon principles derived efficiently from the principle of natural law.

The problem of today’s public stock corporation, is broadly defined as disregard for, or even hostility toward the implications of the principle known by the name of general welfare, or common good. In the worst case, as in the doctrine of John Locke, or the obscene doctrine of “shareholder value” today, the particular heteronomic, virtually anarchist interest, is set above, or even in explicit opposition to the principle of the general welfare. It is the latter type of offense, which expresses pure evil. There lies the essence of the problem posed by “shareholder interest” today.

Rules, when taken into account as principles which are physical in the quality of their effect, are principles in the

---

of Foreign Secretary,” May 10, 1982, Royal Institute of International Affairs (Chatham House), London. Excerpts are published in *EIR*, Sept. 22, 1995, p. 33.

same sense that we might speak of the principles of an ordered series of Riemannian geometries. In economics, they have the effect of determining the characteristic features of the interactions among the components of the relevant phase-space, such as the phase-spaces of the setting and related internal features of the entity so regulated.

What has happened, since August 1971, is the stripping away of those rules of international and national economic and related behavior, which had been established chiefly for the purpose of promoting the national defense and general welfare. The removal of those regulations, as initiated under Presidents Nixon and Carter, most notably, destroyed the moral character of our national economic behavior, by removing those rules upon which our nation depends upon for its freedom from predatory expressions of anarchy.

This is not to propose that immoralities had not existed within the body of regulation extant prior to 1971. Rather, it is to point, that the imposition of immorality for its own sake, underlies the general thrust of those radical changes in our national economy which were characteristic of those two Presidencies, and also of the same prevailing trend in changes introduced since they left office.

That is the area in which “things have gone wrong,” very badly, indeed. Sometimes, the failure of performance of some public corporations, may be attributed to poor choices of management and policy-objectives by stockholders; however, the failure of the corporate sector generally, is a creation of the powers which control government and public opinion.

The poor record usually shown by the public corporation under all general circumstances, relative to the nobler forms of private entrepreneurship, inheres in the dilution of the factor of personal motivation, as I have identified the advantage of the closely held, progressive entrepreneurship a few moments earlier. The bad record which the public corporation has earned over the course of the recent thirty-odd years of Nixon, Carter, and so on, is chiefly a result of very bad changes in relevant law and custom.

Now, we turn attention to the other side of this crisis. I present the changes in thinking about economic matters which must replace the pathological misuse of financial-accounting practices as a substitute for the science of economy.

## 2.1 Mathematical Economics

Given, what I have written here up to this point: how should a government, such as that of the U.S.A. today, apply that to the task of defining a national economic policy?

As a first step here, I shall lead the readers through some “warm-up exercises,” by means of which they might converge among themselves on at least an approximation of understanding today’s most crucial problem of accounting. I mean “accounting” as this task should be approached from the standpoint of economic science, rather than today’s generally accepted financial-accounting methods.

To begin this process, my discussion of these matters with you will include some flat assertions, which are at least rela-

tively accurate. I employ these approximations here for sake of simplicity, to help the readers to reach a preliminary, common understanding of some of the leading conceptions we must bring to bear, in approaching the mathematical side of economic accounting and analysis (as distinct from financial accounting). This will lead us sometimes into prickly thickets; but, experiencing those thickets will help the reader to appreciate the kind of thinking which must be applied to this aspect of either shaping, or simply judging a nation’s economic policies.

For example, first of all, we must abandon the commonplace, hand-waving statistical rant which is all too common, even among most who are actually economists, and commonplace among those economics-illiterate boobs, such as Bartley’s *Wall Street Journal* spin-dizzies, who attempt to pass themselves off as knowledgeable in such matters. Usually, the chatter about statistics which show annual, quarterly, or monthly rates, averages, and so on, might be regarded as suggesting that the speaker is being objective, very factual, and perhaps pompous; but, usually the speaker is merely, as it is said, producing a “wind egg.”

Nothing of fundamental, decisive importance about the economy as a whole, can actually be proven on the basis of statistics pertaining to an analytical framework as short and narrow as a year, or even several years. All studies involving modern economies, must be constructed on a base-line of not less than a quarter-century cycle. No matter how precise the statistics reported as short- to medium-term developments, any shorter base-line than approximately a quarter-century, used for interpretations of the data, means that the result of the study will represent a proportional degree of the kind of incompetence called “a fallacy of composition.”

Nor can any economy be competently analyzed as an accumulation of component elements, such as individual enterprises, or a simple, linear accumulation of industry-by-industry studies. I explain.

In the first example: to bring a newborn child to both the biological and intellectual maturity needed for the practice of a scientific profession today, requires a generation; for such cases, today, a generation signifies as much as twenty-five years. During most of that period, that developing young person will either not fully “pay for their own keep” and education, or, in the alternative, if they are denied that extent of support, will not, on the average, develop to the levels of competence a serious profession now demands.

Ironically, a financial accountant, or kindred sort of statistician, might conclude, that raising and educating such young family members, is a drain on the family’s economy, and an added cost in the family budget, whose effect must be to drive up the price of labor, thus, as some would say, making the economy as a whole “less competitive, less productive.” Were he an accountant from one of his profession’s more recent graduating classes, he might also emphasize, that having more than a handful of such children, is a cause of added expenses which a thrifty economy will avoid as much as possible. He

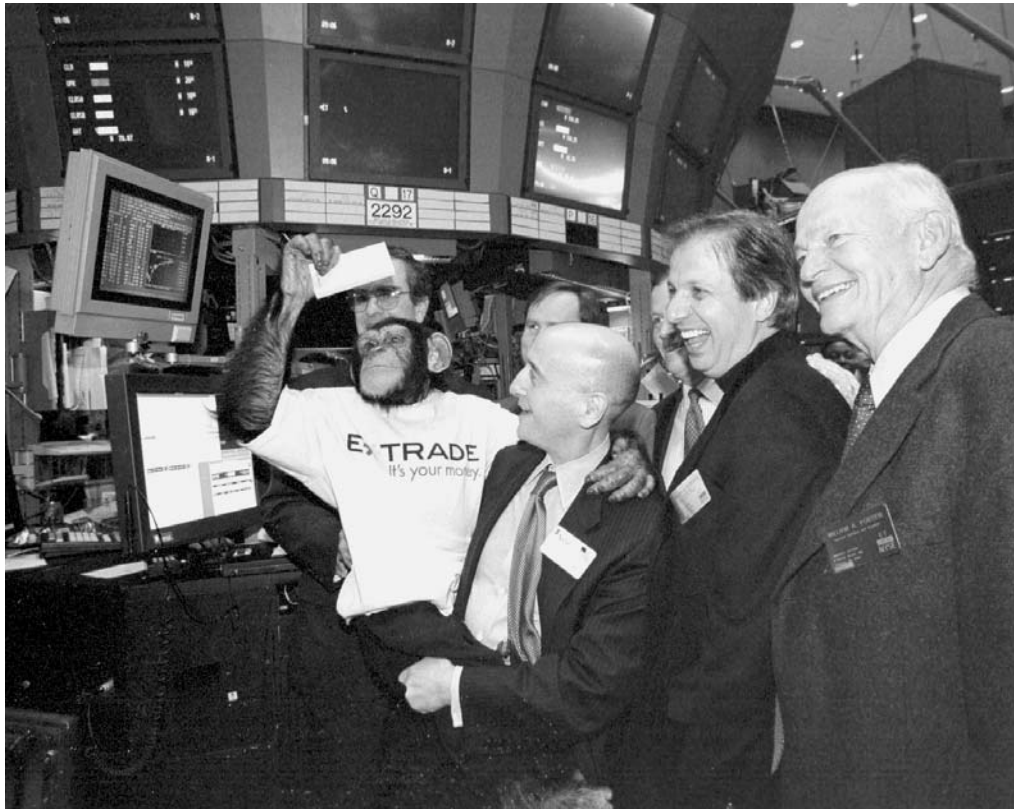

*Actual economics bears no resemblance to the shenanigans carried out on the New York Stock Exchange. Here, E\*TRADE chimpanzee Brooks places a "buy" order on Feb. 15, 2001, as NYSE Chairman Richard Grasso (center) and friends look on.*

might argue: "Who is going to pay the cost of upbringing, during that span of up to as much as a quarter-century?"

In a second example: we encounter a comparable span of lapsed time, between the beginning of a major infrastructural development project, and the point at which the completed project has reached as much as the half-way point in its useful life, prior to needing major upgrading or replacement. Basic economic infrastructure in transportation, power generation and distribution, water-management, forestation, and bringing new urban centers of desirable qualities up to an approximately self-sufficient level of internal functioning, are typical. Educational systems require comparable periods of development to functioning maturity.

For example, to have, or maintain a modern economy, basic economic infrastructure represents approximately half the total capital investment, by combined governmental and private agencies, of the economy as a whole.

For example: housing suited to the needs of those family households raising children, is a long-term investment, signifying that this has, in today's U.S.A. or Europe, a corresponding length of cycle, of about twenty-five years, or more, built into it.

Thirdly: we are faced with similar "life-cycles," some as long, many somewhat shorter, in such areas as production machinery and equipment. Also, any serious work in designing a product and bringing it competently into production for general distribution and use, usually spans several years,

or longer.

We could continue with such examples, but the point is illustrated. The point is, that when a competent economist is discussing, or assessing national economic policy for today, in the case of the economist discussing what the results of a current policy will be, his expressed opinion is implicitly assuming intellectual responsibility for the consequences of what is being discussed, as distant as a quarter-century, more or less, ahead. Of course, he is also considering what we will require and have available to make each necessary step forward during the meantime; but it is the long-term considerations which are paramount.

There is nothing in this with any resemblance to the frantic scramble by those thirty-year-old heart-attack candidates typical of those self-displayed on the New York Stock Exchange. If you have seen that behavior, that pit is not a display of economic thinking, but a feeding-frenzy: a display of deranged young human beings behaving like a voracious pack of piranhas. In real economics, periods such as this year, this quarter, this week, today, each and all have a specific importance, but an importance which can be competently recognized only from the standpoint of the medium- to long-term process in which they are but a passing moment. What we should be measuring, is progress in meeting adopted, long-range physical-economic goals for that time-frame, such as delivering promised goods on time. However, shaping the process on which those goals are both defined and met, is a

long-term process, by the nature of the task.

So, let us abandon the spectacle of that Wall Street looney-bin and its frenzy; return from the very small, to the very large, to the real world. Alice read, "Drink me!" and discovered the effect of each change. Think of the scientifically semi-literate amateur astronomer, who, out of his ignorance, might believe, still today, that a statistical projection from a planet's observed and normalized positions, should enable us to forecast the exact position and velocity of that planet at any specified future date. Since Kepler, we have known that that approach is intrinsically incompetent, unscientific. The proper method of finding the answer for such questions, is the method developed by Gauss for proving that a recently discovered planetary body, had an orbit coinciding with Kepler's specifications for the complete orbital cycle of a missing, exploded planet, which had once existed in an orbit between those of Mars and Jupiter.<sup>43</sup> The only competent versions of the calculus, are those which, like Leibniz's own uniquely original discovery of it, are premised on the exemplary implications of Kepler's discovery of the principle of universal gravitation.

The projection of the values which will be achieved in the near future, depends upon the same conception of a calculus typified by Leibniz's insistence, contrary to the later contention of Euler, Lambert, Lagrange, Laplace, Cauchy, Grassmann, et al., that the differential is intrinsically non-linear, a conception of the calculus consistent with Leibniz's notions of *Analysis Situs* and *monadology*. The reading of the empirical evidence adduced from studying developments in the relatively near-term, must be made from the standpoint of understanding the way in which the system being observed should unfold in the long term. That is the principle which has guided me to the unrivalled success of my method as a long-range economic forecaster.

In other words, economic processes are cyclical in the general sense I have just indicated with the few illustrations I have just stated here. Just as Kepler discovered the principles, including gravitation, which determined the non-constant curvature of the planetary orbits, so we must proceed in all economic forecasting. We must view economic processes as systems, using "system" in the same sense I applied it, above, to our Keplerian Solar System. We must uncover the principles which predetermine the cyclical behavior of the system. In the end, we must evaluate economic performance in the here and now, in the small, from the vantage-point of adducing the cyclical characteristics of the economy in the medium to long term, such as in ranges from five to thirty years. It is those long- and medium-term sets of principles, which provide us, contrary to illiterate forms of popular and accounting opinion, the only possible meaningful assessments of performance in the short term, and locally.

Thus, some of what I have just said reminds you of the issues of method addressed in the topics presented in earlier

sections of this present report. It should. There is more along those lines yet to come.

## The Matter Of Attrition

The ranges of medium- to long-term cycles I have just illustrated, are better understood in light of the implications of two terms which are somewhat synonymous: *consumption* and *attrition*. As I shall show, the two terms have significantly different connotations in practice.

On observation, any physical-economic process is described, in any sensible first-approximation, in terms of sequences of production and consumption. Think of production and consumption as two paradoxically distinct dimensions of chains of sequences. Now, share a few of those general observations.

These sequences are not strictly chronological sequences. The notion of a sequence of events in each chain, is well defined, the lapses of time between the nodes of the chain, are variable. This is one of those numerous cases in scientific study of a physical process, in which so-called "Euclidean" notions of cause-effect relations in space-time fall apart, in which, for purposes of calculation, relative time replaces simply linear notions of clock-time.

In using the term "consumption," the emphasis is upon the destruction of some object in its present form. Therefore, if the consumption of that object is an essential input to the process of production, we must usually assume, in the simplest cases, that what has been consumed must be replaced, if the cycle of the productive process itself is to be maintained at at least its present levels of quantity and quality. "Consumption" sometimes signifies depletion of a natural, or other pre-existing resource; sometimes, this depletion is more usefully classed under "attrition."

The term "attrition" is used generally in reference to the factors of wear, tear, and obsolescence. "Technological attrition" signifies the effect of scientific and technological progress in lowering the relative physical-economic value of previously established technologies, and, also, the lowering of the relative value of the residue of the earlier investments made in facilities and product-designs. So, we define the first case, that of "simple attrition," and the second, "technological attrition." In the case of a modern agro-industrial economy, for example, both kinds of attrition are constantly ongoing.

When I am speaking as an economist, I do not employ the financial accountant's term "depreciation" as a synonym for, or substitute for "attrition." "Depreciation," as used in financial-accounting and related practice, pertains to a monetary-financial value, not a physical value. The importance of respecting that distinction, will be made clearer.

Look now at the similarities, differences, and interrelations between the phenomena of simple and technological attrition as observed within a physical economy considered as a functionally unified whole.

In the first approximation, assume the hypothetical physical economy whose division of labor, standard market-bas-

43. Tennenbaum and Director, op. cit.

kets of consumption of all categories, and related constraints, are fixed. This and similar cases can be represented, as an economy, by the kind of model developed by the work of Wassily Leontief et al. for the U.S. government. All seems rather simple for the practitioner of recent decades' standard classroom mathematics, until we are so cruelly, but charitably<sup>44</sup> rude to our empiricist acquaintances, as to introduce the factor of change, especially notions of change cohering with what I have described above as those of Plato.

Revise the price structures associated with the arrays of commodities, for example. That does much more than change the price-related aspects of commodity production and circulation. A significant change in the pattern of price-setting policies, will lead to changes in the physical relations among the processes, products, and productive labor in the economy as a whole. A related effect is produced by systemic changes in the composition of taxation structures. The most characteristic feature of *the impact of those changes in physical relations*, is not determined by the mere fact of assignment of prices to quantities of actions and things.

Parenthetically. Any sane form of modern economy, is of a form called "protectionist." The general levels of prices are set to accommodate the medium- to long-term capital costs. Wages are set at levels required to maintain family households in the mode which present and future technology require. Taxation is reflected in prices of goods, to reflect such relevant costs as maintaining and improving basic economic infrastructure. Tariffs and trade-regulations are set to ensure similar medium- to long-term effects on productive investment. Relative price-settings are intended to ensure appropriate priorities for categories of (physical, as distinct from merely monetary) capital-investment flows within the economy as a whole. *By contrast, the British East India Company's "free trade" doctrine, as used by Eighteenth and Nineteenth Centuries' England, was applied less to England than to Britain's foreign victims, to ruin the latter by driving the prices of goods produced in those countries to the lowest possible level, to ensure the greater relative power of Britain!*<sup>45</sup>

To shift emphasis, to a deeper level, consider the following. *The essential economic relations within an economy, even one managed as a money-economy, are the physical relations associated with the processes of circulation and production, as to be seen in terms of non-monetary physical principles.* In this domain, the physical principles of chemistry as such, are among the determining considerations in the relations among objects, processes, and people. Vernadsky's geobiochemical description of the development of the biosphere, offers a useful pedagogical illustration of the point.

As stated earlier, Vernadsky's work on the biosphere,

44. Here, I use "charity" in its proper, Classical Greek sense, that of *agapē* as defined by Plato's Socrates and the *New Testament* Apostles John and Paul.

45. Cf. Mathew Carey, in W. Allen Salisbury, *The Civil War and the American System: America's Battle with Britain, 1860-1876* (Washington, D.C.: EIR, 1992, second edition).

emphasizes the range of non-living materials, such as oceans and atmosphere, which exist as natural by-products of the action of living processes. His definition of the biosphere as a biosphere, depends upon the demonstration, that non-living fossil forms, including atmosphere, oceans, sedimentary deposits, and soils, exist only as natural products of the existence and action of living processes. This accumulation dominates the biosphere, from the upper atmosphere, down to an impressive number of kilometers below the surface of the planet. Recall, that the required proof, which Vernadsky supplied, is that this relationship between the living and fossil aspects of the biosphere, were not produced by any other known process in the universe, but life.

Remember, that this biospherical self-development is, in fact, evolutionary in a way a Darwin and his followers could never imagine. Not only do living processes produce the natural products of the biosphere, but the emergence of new orders of species, depends upon those characteristic changes in the biosphere which have been generated as products of earlier forms of living processes. In other words, the possibility of the existence of the higher forms of living species, depends upon the preconditions produced by the activity of those usually lower forms, whose existence antedated their own. This process of evolutionary development could not be understood as an ongoing process, except from the vantage-point of a three-phase series of Riemannian manifolds as I have defined

Why Lyndon LaRouche is  
the world's most  
successful  
economic  
forecaster of  
the past four  
decades.

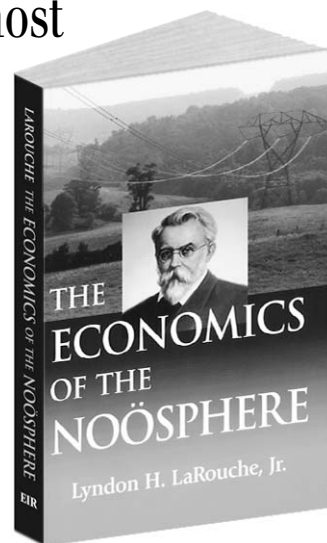

Order from:

**Ben Franklin  
Booksellers**

P.O. Box 1707  
Leesburg, VA 20177

Or call, toll-free, **1-800-453-4108**

Or 1-703-777-3661

**\$20**

plus shipping  
and handling:

Shipping and handling: \$4 for first book, \$.50 for each additional book.

that conception.

In other words, evolution occurred not by statistical accidents, not by choice, but by *intention*, using *intention* as Kepler did, in the sense of the active feature of a universal physical principle. In this case, once again, I signify such an *intention* expressed as a characteristic, determining feature of an ordered succession of such Riemannian manifolds. In choosing a technology, society chooses the *intention* which is embedded in the physical principle; this is an *intention* as Kepler defined universal physical principles. In adopting and maintaining protectionist policies of pricing, investment, trade, and so forth, it is *man's intention, often expressed as choice*, which is paramount, the intention to produce an effect which inheres in the method chosen. An economy combines the intentions embedded in physical principles of the abiotic domain, intentions inhering in living processes, and human, ultimately cognitive intention.

The essential intention behind a successful modern economy, is the relevant intention of the sovereign state. However, this role of intention extends to the state's choice of assigning free will to the entrepreneur; in this case, it is society's intention to provoke the potential use of that entrepreneurship's sovereign cognitive powers of innovation.

Therefore, see physical economy as a product of the existence of that universal physical principle of cognition, which Vernadsky called "the principle of noësis." Thus, for him, the existence of the noösphere was the natural product of the action of human cognitive powers on the combined phase-spaces of the biosphere and the abiotic world, which life was transforming into more and more biosphere. Physical economy is a natural product of cognition (which Vernadsky named *noësis*). Although, as I shall address this a bit down the line, the development of the physical economy has different laws than the development of the biosphere otherwise, there are also important similarities in the comparison of the biosphere with the role of human action in producing the continued development of what Vernadsky named the *noösphere*. Therefore, study of the functional relations among species within the biosphere as a unified process, helps to prepare the mind for understanding the kind of non-linear process which underlies the way in which a noösphere, in general, or a physical economy, in particular, is developed.

With those references to biosphere and noösphere in mind, look at three aspects of the way in which *technological attrition* and related effects are generated within a nation's physical economy.

For the moment, focus on examples, from among experimentally verified discoveries of universal physical principles, which confine their attention, at least principally, to abiotic processes, such as those of so-called "inorganic physical chemistry." Apply to our immediate argument, the relatively simplest version of a Riemannian view of the experimental relationship between proof of a discovery of principle, and the notions of technology derived from the application of such an experimental design to a specific medium. Recall, that

technologies are derived from those specific features of such an experimental design which reflect the existence of such a principle by means of such a test. Focus upon the way in which principles are reflected in technologies, in that specific sense of the relationship. Against that background, consider the following crucial ontological paradox posed by the notion of technological attrition:

*The introduction of a new, superior technology, to supersede a pre-existing design of product or productive process, results in a relative devaluation of that design, but a potential increase in the value of the action, by means of the impact of that change in technology, on the potential of the economy as a whole.*

Both the lunatics known as anti-technology Luddites, and even, to a less extreme degree, modern trade-union ideologues, have opposed technological progress "at the point of production," as "taking away jobs," but have, at the same time, usually demanded the promotion of the general benefits to all, which those changes foster. *A useful paradox!*

*Think back!* to what I have written on the subject of ontological paradoxes, here earlier. The existence of any true ontological paradox betrays the lurking presence of a universal physical principle. The error is the fallacy of thinking of economic values in terms of "the point of production." The relevant principle is implied by the general statement, that the application of an advance in human knowledge to any part of the economy, is a resulting improvement in the economic process considered as a whole.

The pathetic error of the referenced type of trade-union ideologue, is his, or her failure to recognize that, *on the condition, that the economy is governed by the constitutional principle of the general welfare*, the result of any submission of economic policy-shaping to the standard of introduction of a valid discoveries of universal principle to the productive economy, is, at the very worst, a relative improvement in the standard of living of the labor-force as a whole. Remember, from this point on, that every argument I make here is premised on the rule, that the policies of government and the generally prevailing standard of economic practice otherwise, must cohere with the principle of the general welfare, as I have identified that above.

The foolish trade-union ideologue, would probably argue: "I'm not talking about the general welfare; I'm talking about feeding my family here and now!" Similarly, we hear foolish, actually immoral people saying, "I can't be bothered with what happens to the nation, or what happens in other parts of the world. I have to think about my family and my local community!" So, a poor, misguided slave, might think the most important goal, is not the ending of slavery, but a better slave's cabin for his family, or a slave-plantation where conditions are better.

The ever-pandering moralizer, or the perennial "practical politician," would be outraged to hear me argue that point. He would say such things as, "Have you no respect for the family! Have you no respect for those people's feelings! How



can you be so insensitive!” Let me rebut such objections in a way which may seem cruel, but is absolutely necessary, both morally and practically.

Compare those critics’ argument to the hypothetical case of the poor fool who insists he “can’t be bothered with bridges; I just have to get to the other side of this chasm.” “Who cares about national railway systems, the far-away power plants which send us electricity, or foreign markets? I have to worry about things on my job, my family, and the community in which we live.” In other words, they are taking the pathetic attitude expressed by the dangerously silly Adam Smith, in the passage I have cited, above, from his *The Theory Of The Moral Sentiments*. They, like the followers of John Locke or Adam Smith, are showing behavior more appropriate for a mother monkey clinging to her infant, than the behavior of a cognitive human being.

Thus, to sum up my line of argument so far, the solution to the referenced ontological paradox is, the recognition that, first, changes in any part of the physical economy, change the characteristic behavior of that economy as a whole, and, second, that it is the change in the characteristic action of the economy as a whole, which is the primary determinant of the net effect expressed in the local aspect of that economy.

It is from that standpoint that the most typical problems associated with the notions of simple and technological attrition, are to be understood.

### **Simple Attrition And Riemann**

The point of reference from which a case of simple attrition is customarily defined, is the exhaustion of so-called “raw materials,” chiefly materials which have been made proximately available to mankind as natural products of the biosphere. This includes, of course, the atmosphere, oceans, most sedimentary deposits, and so on, which came into existence, chiefly, independent of mankind’s witting interventions. There is little doubt among economists and others today, that we must either replace those “raw materials” from sources we have depleted, find substitutes, or supersede our dependency upon them, the latter by society’s willful economic leaps to qualitatively higher states in science and technologies.

However, by convention, we apply the same notion of depletion to exhaustion of some man-made improvements in what is popularly identified as “nature,” such as improvements in land, forestation, water-management systems, and so on. This use of “depletion” for simple attrition in man-made systems, is most clearly appropriate in respect to systems which are currently defined as “managing the environment.” Maintaining rivers and harbors, control of air and other pollution, and control of variously man-made and natural catastrophes, such as pestilences and infectious agents of diseases of plants, animals, and man, earthquakes, floods, and so on, are typical costs whose payment must be built into the design of the economy, and the setting of prices.

Cases such as simple attrition of the functional qualities of urban areas, especially those aspects whose maintenance

is attributable more to the general functions of human habitation, rather than some business, or business-like purpose, may be treated conveniently as matters of depletion of the environment.

The ambiguities which arise in discussing this topic’s area, arise chiefly because this includes areas of relevant overlap of biosphere and noosphere. Where that which is being depleted, is clearly a product of the biosphere, rather than the noosphere, the conclusion is clear. Where man has introduced what is functionally an addition to the repertoire of the biosphere, such as “making the desert bloom,” there are ambiguities.

Take as an example, the case of a conceivable science-city research colony on Mars. The immediate purpose of that science-city, would be as a functional bridge to research and special functions in the zone of the Solar System beyond Mars, especially in a very broad, and more refined exploration of the celestial spectrum through very-large equivalents of radiotelescopes, and kindred devices. The immediate mission would be essential measures in aid of discoveries of universal physical principle which could not be accomplished from Earth itself.

To create such a scientific-research base on Mars, or preferably more than just a bit under its surface, would require creating an environment there suited for human beings’ survival and functioning. The use of both pre-existing and introduced elements of the needed environment of that research base, would fall into the category of costs incurred as depletion of the functional equivalent of a habitable man-made biosphere. In other words, “a synthetic micro-biosphere.”

The distinctions I have just outlined, are of the character of “reasonable approximations.” Sometimes, we must make such approximations, and rely upon them as standards of practice. In the long term, that is not satisfactory. We must bridge such areas of ambiguities by locating a subsuming principle. This latter objective requires returning our attention to concentration on the notion of an ordered series of Riemannian physical geometries subsumed by the interactions among three distinct qualities of phase-spaces: abiotic, life, and cognition. The following discussion should help to clarify this type of problem.

What must be clarified and emphasized here, to overcome the referenced ambiguities, is the importance of this philosophical outlook on our universe, for removing certain mysteries respecting the actual way in which an Earthly physical economy may succeed, or fail, in the relatively distant future, as in the here and now. Often, a result to be secured in the future, will not be possible unless the relevant action is taken now. Neglect of that wisdom, has led entire civilizations, such as Byzantium, to its doom. Out of respect for such things, the following background discussion is needed at this point.

In the case of Earth’s biosphere, the “forces” associated with the action of life as such, are ostensibly weak, when compared with the relative scale of apparent raw force of the abiotic domain. Yet, Earth attests to the ability of the rela-

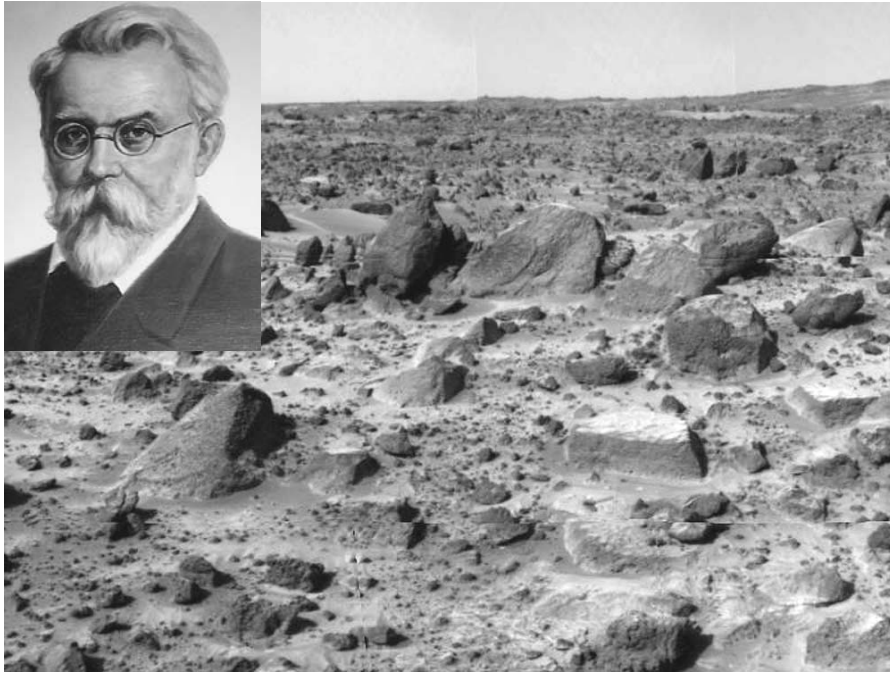

Vernadsky (inset) investigated how the biosphere and the noösphere transform the Earth. Today, the construction of a research colony on Mars, would open up the possibility for discoveries of universal physical principle which could not be accomplished from Earth itself. Shown here: The Mars landscape, as photographed by the rover Sojourner in July 1997, shows evidence of the action of water. The group of rocks, from the lower left to the middle, are all pointing in the same direction—a phenomenon most simply explained by the action of large amounts of rushing water.

tively weak forces of life, to persist in their assimilation of the abiotic. Similarly, from the outset, cognitive man's cognitive powers represented a relatively weak force, relative to what some might describe as the "raw forces" of the biosphere in general. Yet, the relative power of man over the Earth has increased greatly, and ultimately without limit, a power made possible solely by the Promethean power of cognition.

As I have emphasized in earlier locations, this argues, implicitly, that *relevant crucial experimental evidence shows, that the principles of cognition and life exist independently of the assumption of a preceding existence of the principle of an abiotic universe*. In that sense, then, all three phase-spaces, abiotic, life, and cognition, existed at whatever might be assumed to pass for "the beginning" of our universe. (In fact, nothing could have existed outside, or "before" that universe. "Outside that universe," the very names of time and space, or matter, become the meaningless jabber of mindless fools.) However, since the same crucial-experimental evidence shows, that the three phase-spaces are efficiently multiply-connected, in Riemann's sense of multiply-connectedness, there never was an abiotic universe in which the presence and efficient intervention of the principles of life and cognition did not exist.<sup>46</sup>

This irony was already addressed by Plato, Luca Pacioli,

46. Thus, as in *Genesis* 1: man and woman created equally in the likeness of the Creator, and the Gospel of *John*: 1,1. Thus, the concept of a relativistic "simultaneity of eternity" in Christian theology. Thus, Plato's *Phaedo* and Moses Mendelssohn's *Phaedon*. The significance of this is not merely that the Mosaic and Christian conceptions so identified, have been at the root of the emergence and development of today's globally extended European civilization, but that the evidence of modern science is that those ancient influences have put man on the right track.

Leonardo da Vinci, and Kepler.<sup>47</sup> The ontological paradox, of the juxtaposition of the six-sided snowflake to the five Platonic solids,<sup>48</sup> reflects the principle of a universe composed inclusively of abiotic principles and life, as multiply-connected. *The irony of the juxtaposition of entropy attributed to a reductionist notion of purely abiotic processes, with the anti-entropy characteristic of both life and cognition, is not an impossible contradiction, but rather the fact that the universe as a whole subsumes three distinct, but multiply-connected phase-spaces, phase-spaces which have always been efficiently multiply-connected!*

To resolve what are the immediate functionally significant aspects of what must be for many readers, initially, those apparently paradoxical considerations, *we must recognize what should be the obvious fact, that our physical economy is not something local to the U.S. territory and population in the immediate here and now; even in its most minute detail, the U.S. economy is an expression of a functional interaction with the universe as a whole.*

This connection is clearest when we take into account the historical fact, that today is the cognitive outcome of all our yesterdays, a tree whose fruit is all of humanity's tomorrows. We must use the lesson of the role of approximately quarter-century cycles, as the basis for judging the centuries-long, or longer significance of what is occurring today. We must recognize those longer, cyclical or cyclical-like processes of the past and future alike, and think of such extended foresights as crucial for defining today's choices

47. Plato, *Timaeus*.

48. Kepler, op. cit.

of our nation's and civilization's future.

As I have emphasized in earlier locations, and again in earlier portions of this report, the significance of an act of verified discovery of a universal physical principle, is that it occurs as a change in a multiply-connected manifold of universal principles. Thus, that past which effected those discoveries, lives, and implicitly also breathes, in the present moment of each of us sharing that accumulation of knowledge.

Although, I doubt that anyone is more dedicated than I am, to the form of modern sovereign nation-state and economy projected by the circles of our Benjamin Franklin, I view the existence of that man-created republic, not as an arbitrary act of the founder's will, but as an efficient, and necessary existence within the continuity of the universe, as an existence which has an intended, necessary mission, as a necessary instrument for the betterment of the future of all mankind. I view these United States, as an existence defined by the opening paragraphs of our 1776 Declaration of Independence and the 1789 Preamble of our Federal Constitution. It is, for me, an existence in respect to the past and future of the universe upon which we are acting, from the place where we stand.

I think of the necessary existence of life and cognition at whatever might pass for "the beginning" of the abiotic phase-space of this universe. In the future, if our civilization survives to thrive, mankind shall go far into what we call the space of this universe, changing things where we go, just as life and cognition have changed this Earth we inhabit. Thus, if we examine the known and discoverable peculiarities of the processes from which life took over this planet increasingly, and man has taken over and transformed the biosphere, we can look backwards and forwards, with the following thought in view.

We must study the preceding billions of years of so-called evolution of the biosphere, and of the noösphere, for the purpose of discovering a principle reflected in the pattern of developments so examined. We must discover a corresponding, relevant notion of universal law. We must ask ourselves the question: *What has been the intention of this universe, in bringing us, a cognitive form of life, into the role which experience should help to show us were the intention we should have better been consciously applying to our policy-making all along?* What should we destroy, by consumption, and what must we perpetuate, and also invent, to the purpose of furthering the adducible intention for mankind's work, as this might be expressed by what we might learn from study of the universe's past in this way?

Restate an implication of what I have just written. It is, unfortunately, more or less commonplace today, to think of economy and society in terms of the assumption that there is some natural state of nature existing prior to, and outside of mankind's intrusion into it. Some are, therefore, affrighted when the suggestion is made to move a large river's flow, or make the desert bloom; they say, "Mother Nature will punish us all if you do that to her!" If we think clearly about that, we

see that such expressions of faith in "Mother Nature's natural will," are merely infantile superstitions, like bad fairy-tales. The record of development of the universe is a record of development through destructive consumption of the scaffolding which the universe had previously constructed to reach some intermediate goal.

We have the means to choose to change things, from the way they have been; but, we are responsible for the effects of what we do. The importance of such universal reflections becomes apparent once we seriously consider the possibility of sustaining human life for some extended period in a place as relatively tolerable as Mars might be made to become.

We must, therefore, choose that universal outlook, respecting past and future, as the standpoint from which we reassess the worthiness of those terms of approximation we employ in defining concepts such as "attrition." There are, indeed, deeper principles which, once discovered, will remove the smell of ambiguity from the so-called "practical" definitions we might employ today. That does not signify, however, that we should not scrutinize the approximations from the higher, more universal vantage-point I have just summarized. Thinking in those ways, about matters for which we have indications, but only such indications, is not to be considered idle speculation merely because important answers remain undecided. What is important, is the attitude we take toward the need to clarify such questions. That commitment to seek clarification, rather than brush the unresolved issues aside, is properly recognized as "conscience." It were better, more exactly named "epistemological conscience"; it is the notion of what I have represented, by example, in the manner I have conducted the immediately preceding discussion.

### **Technological Attrition**

What I have just written, respecting "epistemological conscience," carries us forward to the matter of what I term "technological attrition." Ultimately, from the epistemological standpoint which I have outlined immediately above, all economic attrition is properly defined as technological attrition. The two conceptions, of technological attrition, as I define it here, and my treatment of the applicable notion of a three-phased Riemannian manifold, should be combined to define what the term "mathematical economics" ought to signify.

As I have already emphasized, the essential fallacy pervading the work of most of those who consider themselves expert in economics, is the presumption that there is some way, in which to derive a cause-effect connection within economic processes either from financial accounting, or from cost-accounting methods premised upon financial accounting conceptions. *Contrary to today's popular opinion, there is nothing intrinsic to the nature of what are priced as costs and expenses, which either accounts for, or should account for the prices of the relevant sold goods or services.*

For reasons I shall include in the following discussion, high-speed electronic data-processing apparatus (EDP)

should be a boon for those who understand the need to supersede financial accounting methods by physical-economic ones. Unfortunately, since the history of the development of EDP systems was controlled by those with a proprietary interest in peddling linear systems-analysis applications, the singular benefits for which EDP systems might have been developed, to provide crucial qualities of assistance to physical-economic and related administrative functions, were not adequately promoted. The chief offenders on this account, were both systems analysis as such, and the refusal of the financial-accounting profession to recognize that the functional character of economic reality existed only in physical economy, outside the definitions, axioms, and postulates of financial accounting.

In a form of cost accounting which conforms to scientific requirements, for every element of the transactions within an economic process, two sets of books are required, one for physical reality, and the other for the merely nominal reality of financial-accounting considerations. In both sets of parallel entries, for each event, a price, or priced cost is identified. Otherwise, the two systems are qualitatively irreconcilable, functionally. A physical-economic accounting treats as primary, the functional expression of physical relations, rather than financial ones.

For this reason, the development of large-scale, high-speed digital computing apparatus should have become a great boon, a way of bringing down to reasonable levels, the human effort required to correlate the doubled array of respectively differently defined sets of data required, and the different kinds of functions performed. To perform the needed kind of economic analysis, as distinct from financial and cost-accounting analysis, we must perform detailed mathematical operations which are much too cumbersome, humanly speaking, and therefore far too costly, for anything but very high-speed EDP capabilities.

Now, look at what is involved.

The most simply defined aspect of the problems thus incurred, is of a principled, rather than merely a procedural character. The issues of conception and method are those typified by that irreconcilability, which I have referenced repeatedly, between the methods of Kepler, Leibniz, Gauss, and Riemann, on the one side, and those of the empiricists Euler, Lagrange, Laplace, Cauchy, Clausius, Grassmann, Helmholtz, Boltzmann, et al. on the other. Financial accounting, and related expressions of cost-accounting specify or imply, as Euler's attack on the Leibniz calculus did, an axiomatically linear cause-effect relation between elements of cost-expense and "value added" at either "the point of production" or equivalent notion of a local activity-center.

In physical-economy analysis, we must correlate what is often the apparently costly change in a local practice, with the overwhelming, contrasting, relative gain that local change contributes to the economy in general. For example, making our universities effectively science-driver institutions for the economy as a whole, would substantially increase the amount

of human effort and capital investment required to upgrade the universities, the labor-force, and so on, to this effect. This would require a significant improvement in the net physical standard of living of the family households in general, even at the expense of short- to medium-term "shareholder interest." However, the rate of growth of the economy per capita, and increase of wealth per square kilometer of that territory, would vastly outweigh the added costs incurred, and greatly increase the rate of profit and growth over the medium to long term. Congressman Jack Kemp and his "supply side" cronies had everything backwards and upside down.

The addition of apparent costly technological improvements at some local part of the process, is often necessary to gain a more than offsetting advantage to the larger economy. Excessively localized decision-making, as by zealous but narrow-minded cost accountants, thinks of improvements in the firm's, or nation's economy in terms of an aggregation of cost-cuttings at many localized points of the process. As a matter of principle, that approach is usually a foolish one: eliminating waste, and cutting the nourishment of essential flesh and bone, are not to be confused with one another.

Take the case of the cutting of the costs of design engineering by the introduction of what is called "benchmarking." Linearized computer simulations are used, instead of the apparently more costly experimental approach of the traditional design-engineering function. The elimination of the traditional function of the design engineering, is a short- to medium-term reduction in corporate cost accounts, but a medium- to long-term catastrophe for the economy as a whole.

It used to be said, in Britain, "penny wise, pound foolish!" Speaking of "foolish," consider the terrible folly called "out-sourcing."

The intention of "out-sourcing" has been to shift production from modern economies, to cheap-labor markets. The general effects are: to take down the productive potential of the modern economy, while providing employment and income to some sectors of the cheap-labor-market economy, but by a net medium- to long-term looting of that cheap-labor-market economy as a whole. Not only does the importing economy lose income by shifting production to out-sources; the productive potential of the national economy which shifts to out-sourcing, is depleted, with effects such as those seen lately in the catastrophic increase of the U.S. current-account deficit.

That set of combined effects was masked by a kind of mass-brainwashing euphemistically called "new economy." I summarize.

Over the course of the recent thirty-odd years, since about 1964, the myth was popularized, that what is sometimes called "cybernation" is now destined to replace the old smokestack-industry and family-farm economy of the earlier Twentieth Century. "Cybernation" would generate a genteel abundance for white-collar incomes, while blue-collar employment dwindled into virtual non-existence. The spread of that and related ideologies, dulled the minds and crippled the morals

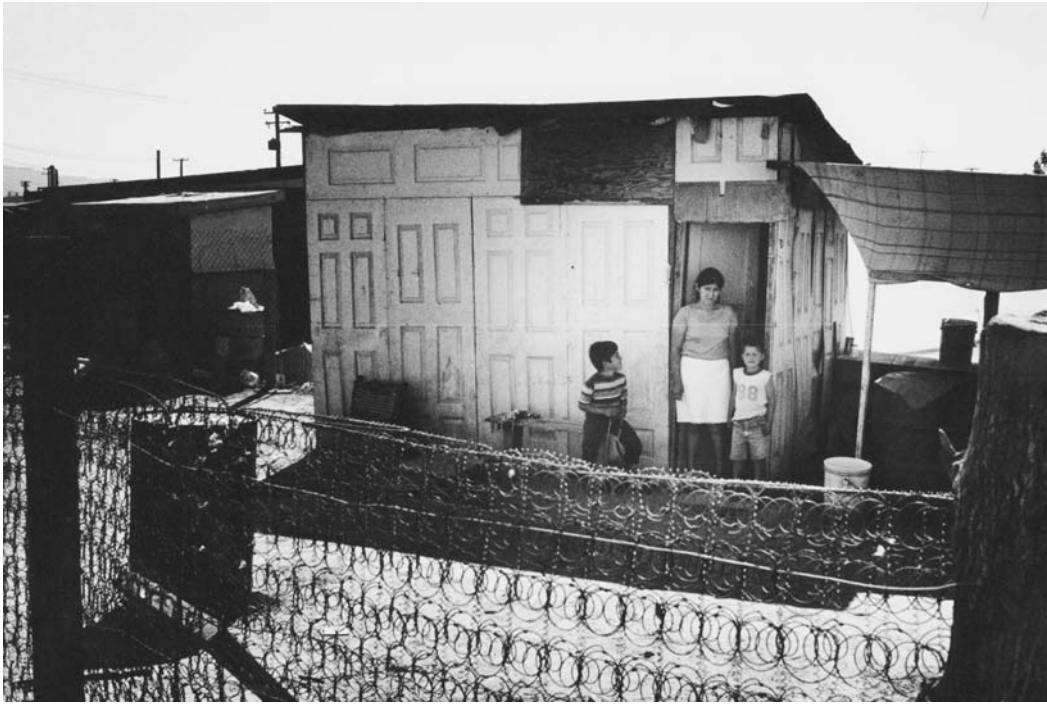

*The shift of production to cheap-labor markets, through “out-sourcing,” loots nations such as Mexico, while lowering the productive potential of the importing nation, the United States.*

of what became the majority of the population in the U.S.A. and other countries. In this way, brainwashed minds saw the evidence of a growing, global economic catastrophe, but, in industrialized and developing nations alike, increasingly worse was taken as evidence of healthy change for the inevitable better.

Now, the “new economy” bubble of 1995-2000 has undergone a rather sudden, and permanent, multi-trillions-dollar collapse. It never actually earned a profit; it was essentially a financial bubble, and the supposed profits were chiefly purely speculative financial capital gains. Once the speculative bubble popped, the “new economy” collapsed, with trillions of purely nominal assets lost very quickly. The problem was not that data-processing and related equipment is not useful; the problem has been, that most of that investment was not used in ways which increased the physical-productive output of industries; it was used largely for a market, a market found largely in the economically parasitical expression of new dimensions of personal amusements, which was being built up, artificially, while shrinking the productive sectors of the economy which might have absorbed such product in a way contributing to increase of the net national physical output and related rates of productivity. The historian would recognize, that the promotion of bread and circuses in ancient Rome, brought down the Roman Empire in a manner echoed by the “new economy” and related recent expansion of the mass-entertainment “industry.”

My line of argument here, should not be read as a suggestion that we must use EDP to weigh every jot and tittle of local practice against the estimatable effects of local change on the economy as a whole. It signifies chiefly two things. As

we depart the fantasy-land of “cybernation,” we should set up model studies which show the kinds of such interactions typical of healthy forms of entire economies, and sectors of those economies. In other words, relevant models as guides to policy-thinking. Second, that improved accounting methods be developed, which are consistent with the kind of thinking about economy I am illustrating here.

Focus upon the physical reality of the production-process. Consider two aspects of this. Consider, first, the local junction at which an act of production of a physical output is occurring. Consider, second, the interconnections of that act of production with the economy as a whole. Shift focus from the false assumption that economic cause-effect relations are linear, in the way today’s generally accepted financial accounting supposes. Focus on the intrinsically non-linear functional relations of production, functions which include and are often comparable to the kinds of mathematical forms associated with physical-chemical reactions.

In physical reality, the principal consumption-production conversion-relationships are intrinsically non-linear, in the sense that that image of physical-chemical reactions suggests. Take the simplest kind of local relationship between consumption and production. We have four principal elements coming together at that junction: 1.) There is that which is being consumed as an input at that junction. 2.) There is that which is being produced as the output of that junction. 3.) There is the mode of production being employed, such as a machine-tool. 4.) There is the skill and intelligence of the operator functioning at that junction. Consider the simplest case, in which the operator supervises the operation, without intervening into the internal features.

The connection between the consumption and production expresses one or more technologies. These technologies express an *idea*, which is one or a combination of universal physical principles, which are given substance in a combination among principles and media, which we know as a specific technology peculiar to that combination of principles and media. This technology, applied to the material consumed, produces a transformation in the consumed input, which is the output of that process at that junction.

In a Riemannian physical geometry, each universal physical principle corresponds to a “dimension” of the manifold. The combination of such dimensions with the characteristic action of the machine-tool, or equivalent, generates the product. This process of transformation is, by nature, not a linear one.

Frequently, matters are more complicated. For example, the operator may intervene in the process, performing an act of judgment requiring developed knowledge and skill, thus introducing added non-linear factors into the process.

Each product being produced belongs to a cycle of production, a cycle beginning in the development of a product of that design, which, in turn, subsumes the cycle of delivery of materials, components, and so forth to the process of production of that product. Meanwhile, the process of production, as it exists in its present form, is being used up in various senses of being used up. This using-up process also has a cyclical characteristic. A particular act of production may be only an aspect of a production-process which includes predecessor and successor stages. This, too, involves cycles.

In practice, all of the decisions implied in bringing together the totality of actions and considerations required for competent production of output have been brought into being as acts of human judgment. This complexity of deliberations may not be actually considered at the time and place the act of production is occurring, but they are decisions which exist implicitly at that time and place, even if they are not all being consciously considered at that moment.

In fact, the way such bundles of ideas are expressed as behavior is premised on types of actions, which have usually been worked out at various points in time earlier, and have become a pre-tested type of behavior on which those involved rely. The new decisions to be made at any time in the cycle are thus reduced to a relative few among all those implicitly expressed.

The special, non-financial studies embodied in these physical considerations are properly the subject of experimental studies of types of productive and related behavior, in which a large number of such considerations are actually worked through. This process is often one best conducted with aid of EDP.

That is the simpler aspect of the challenge. Now, shift attention to a different view of the same production process; instead of considering a product generated at a local “point of production,” consider what the economists of the Hamilton-

Carey-List American System of political-economy defined as *the productive powers of labor*.

## Productive Powers Of Labor

The traditional, and related industrial-engineering estimates of relative productivity, are rule-of-thumb guesses, often useful notions for addressing economic matters in the small; however, they can be worse than useless, even for internal uses by firms, unless tempered by considering the economic process in the large. Even at their best, they are paradoxical, and often more or less fatally so, including cases of individual firms. For all serious policy-deliberations, a different approach is required.

Among the typical fatalities of that category, were firms which began to be self-undermined, when their direction by a strong, entrepreneurial leader, was superseded by a “family interest,” or a Wall Street “shareholder interest.” Little has been more successful in bringing a once-successful enterprise to ruin, than that replacement of an effective, entrepreneurial quality of leadership by the profit-maximizing fungus of “shareholder interest.” Simply said, the easiest way to increase distributable profits is to side-line investments in the technological and related improvements of the future, and, as much as possible, even turning depletion and depreciation into “distributable earnings.” The ideology expressed in such forms as, “We own the company, don’t we?” often underlaid the policies which pushed the enterprise into obsolescence, and, then, the fringes of doom.

The problem to be faced is the same deadly fallacy of prevailing ideology, which I have found it convenient to identify through the image of the foolish clone prince. Let me remind you, briefly, of what I have pointed out on that account.

The characteristic form of the problem of society which most often dooms, or nearly dooms a nation, a culture, is the prevalence of an habituated, usually popular, false ideology, such as the widespread, pathetic belief in a doctrine of “free trade” in the U.S. today. When that ideology is combined with widespread tolerance of an aggravated ideological factor, such as the doctrine of “shareholder value,” an entire nation, even a leading world power, may be self-destroyed as a consequence of that belief alone. The popular misconception of “productivity” among professional management consultants and related categories today, is such an implicitly deadly expression of the impact of pathetic elements of a widespread ideology on policy of practice.

The issue is an issue of method. The issue of method here, is the same emphasized repeatedly in the course of this report so far. There are two facts of physical geometry which must be applied to any statistical array of ostensibly related facts. The first, is that the meaning of any observed facts, is determined by the characteristic features of the system in which those facts appear. The most commonplace forms of pernicious ideology among economists, as also widespread in

mathematical-physics practice still today, is the insistence on reducing analysis of observed events of a process, to a geometry rooted in a combination of an implicit belief in sense-certainty, combined with tendentious predetermination to reach conclusions which are in accord with some prevalent system of special belief.

As a pertinent example of that syndrome, take the referenced case of the myth of the “new economy,” as a relevant example of the way in which pathological forms of induced special beliefs, myths, are blended with the influence of sense-certainty, to bring an entire nation willfully to the brink of its own destruction.

In this case, the pathological factor of sense-certainty underlying the spread of the “new economy” delusion, was identical with that of the John Law-style bubbles of early Eighteenth-Century Britain and France, or the U.S. “pyramid club” mass-mania of the close of the 1950s. The powerful motive of personal greed underlying the spread of the “new economy” madness, was pure and simple greed for money as such. In my study of the relevant evidence available to me and my associates over the recent six years, there has not been a single case of a person duped into fanatically stubborn belief in the “new economy,” who was not expressly motivated by statements to the effect: “That money is there, and I need it. I have a right to get my share of it, and if you are standing in my way, I hate you!”

This lunacy included members of the U.S. Congress, whose morning and noonday prayers were lifted not to God, but to a still higher authority, “The Market.” Admittedly, they often attempted to mask the true nature of such religious devotions. They would cite surrogates for money per se, such as “My re-election in 1992 will depend upon money I gain from contributors who are depending upon The Market,” or the simple citizen’s: “I need the money to supplement my poor pension,” or, even, perhaps, “my welfare check.”

There were those who spun out complex rationalizations, purporting to show that “the new economy” was a qualitatively new source of real wealth. Scratch the surface of their spin; underneath, the theory was only a way of dignifying a less complicated, base passion: “I want that money!” The last-ditch defense of their lunacy was: “I desperately need that money!” Why do so many Americans lie, even perjure themselves: “I had to do it; I needed the money, and this was the only way I could hope to get it.” They did not call it “greed”; they called it “green.” Others who did not share that delusion, would nonetheless nod sympathetically to hear such folly; they wished to show sympathy for the poor deluded fellow’s “feelings.”

Now, that “new economy” is dead, almost as dead as a Confederate three-dollar bill. Yet, as a silly man might still long for a lover, or a mother, who had abandoned him, even years later, the “new economy” has left him, but his insane lust for her return, remains unquenched. People with such delusions are dangerous, especially when they gather in

large numbers.

One can never really understand an ideology, until one has grasped the role of passion in bending the victim’s will to the power of a delusion.

The question was posed to me during my stints as a management consultant, during the 1948-1952 interval, when I first adopted the notion of *potential relative population-density*. I improved upon that conception, in 1953, through wrestling with the implications of Georg Cantor’s 1880s definition of the notion of a *transfinite*, and the adoption of Riemann’s habilitation dissertation as a better way of situating the notion of a transfinite than Cantor had done. This concept did not provide me with exact values; as I shall explain here, it protected me from being duped into adopting any of the widely recommended, false ways of measuring what was called “productivity.”

At that point, I was satisfied that that concept of potential relative population-density, defined in those terms, was a fully satisfactory approach to defining productivity in a way which subsumed both the macrocosm and microcosm with equal effectiveness. This provided the conceptual basis for the initial, 1956-1960 development of my successive approaches to long-range economic forecasting.

This measurement has principally three components: *physical output per capita* (of labor-force, of total *population*), per square kilometer of total *territory*, as correlated with relative *demographic composition of population*. This measurement is not a number, but a conceptual standard of comparison. Sometimes, the greatest fool is he who deludes himself that the best measurement is always an exact number. Often, especially in the cases of systems, such as systems of changing human behavior, which are undergoing qualitative changes during the interval measurements are being attempted, the best proof is not quantitative, but qualitative. It was a method for determining what was relatively better or worse, and why.

I shall not detail the essential features of a system of mathematical physical-economic calculations which follows from the considerations I have set forth in this report thus far. I shall limit myself here, to a few observations of a qualitative nature, which should provide the reader a sense of the direction in which such a system takes us.

The potential which I have just represented, is, first of all, principally a function of the accumulation and application of discovered universal physical principles. These principles pertain, secondly, to the abiotic, living, and cognitive manifolds, and to the multiple connectedness of this manifold as a whole.

In both of these two references, the active question is that of relative level, and rate of change among successive levels. Restated: We are back at the notion of change, as Heraclitus and Plato defined change, as primary. The crucial feature of this approach, is the emphasis upon the cognitive function, as pivoted centrally upon the accumulation of verified discover-



ies of the universal physical principles associated with the three phase-spaces: abiotic, life, and cognition itself. We should not be overly concerned with exact numbers; our objective must be to discover a useful estimate of relative scales. The object is not to predict exact numbers; the primary object is to foster qualitative improvements, and avoid retreats into the delusory certainties of oversimplification.

A real physical economy, is not a fixed system. It is a living, cognitive process, which is constantly undergoing change. Therefore, no exact outcome, a year or more ahead, could be adduced from a change introduced today. The change we may introduce, will set off ripples of changes in reactions throughout the system. Thus, by the time any chosen future date is reached, many of the changes which will have occurred during that interval will result in a different effect than the change on which the attempted forecast is premised. It is not numbers, but relative direction in changed values of numbers, which is our proper, primary concern.

The most exact measurements in physical science, are those unique qualities of experiment, which demonstrate the validity, or error, of an assumed hypothesis. Does an assumed universal physical principle exist, or not? On this class of subjects, we can and must be precise in our measurements. The demonstration of the validity of the definition of an ontological paradox, is among the most crucial of all challenges to measurement, as the case of Kepler's discovery of the character of the orbit of Mars. An experimental proof of an hypothesis, is also crucial. In other matters, in which the roster of relevant principles is not clear, the demand for exactitude for its own sake, is often a delusion. *Before you measure too precisely, be certain that you know what it is you are measuring.*

An estimate of the relative change in value of the productive powers of labor, is premised on taking into account the comparison of the incurred costs of productivity, with the changes in the output of labor, as output is measured in terms of physical, non-monetary content of market baskets in terms of the same physical, not monetary costs as the input to productivity. This is by no means a simple matter of today's ordinary cost-accounting methods.

Our initial concern, in studying what appears to be the cost of production, is to question whether the allowed costs are each excessive or understated. Some illustration of this point is necessary.

Since economy is defined in terms of combinations of long-term and lesser cycles, the estimate of productivity must go beyond what is being produced more or less immediately, to take into account the future effect of choosing to produce that item in that mode and manner.

For example, the operatives employed by a manufacturing firm have families, often including children. What is the effect of the standard of living of that operative upon the development of the future productivity of the children of that family, when they emerge as adults? What kind of education of our households, is required for the goals which we should wish

our society to reach a generation ahead, or longer? What quality of education are these children to be provided, for how long? What are the relevant conditions of life in the home and neighborhood, as these bear on what we should hope to achieve as improvements in society by the time these children reach maturity? How should residences and neighborhoods be designed and developed, to foster the better cognitive development of the child? The provision of privacy for concentration by members of the household, for example? And, so on.

Then, we must consider public health, not only in terms of public facilities, but as the well-being of each member of the community affects all others in that community, and the economy, too.

Or, at the legendary "point of production," how should the methods applied to the design of the workplace and its function be selected, to enhance desired long-term as well as immediate objectives?

Where can a change of design in process, product, or circumstances of life, foster important improvements in long-term as well as short-term physical-economic productivity? Do not assume that an existing, or customary view of a standard of living for households in general, or of certain types, is historical evidence of a wise choice of assumed value by society so far. We require a pervasive attitude among our people, especially people in leading positions of influence, an attitude of seeking out many small local changes from well-established precedent, which will contribute a large net technological benefit to the economy and society as a whole.

In this approach, we must weigh two kinds of effects of the changes on the society as a whole: near-term and long-term. Our primary objective should be long-term gains, gains realized over the span of a decade or generation, or even much longer. However, we must also weigh long-term gains against the burdens those policies impose upon the society during the short to medium term. Fortunately, a well-informed society will discover that this is not an impossible intellectual task. We may not know all of the options which might turn up in the future; but, we can and should know the likely types of changes available to be reached during the span of a generation ahead, or even longer.

For example, a modern power plant may require five years to construct, and will operate for a quarter-century, or longer. A major water-management project, such as the famous TVA, may require longer to complete, and, properly maintained, will last for more than a century. If those discoveries of principle which might have the greatest impact on the future, are not known precisely, in most instances, we already know, or should know, the area in which the most significant among these are likely to be made, and the general nature of the impact they will represent a quarter-century and longer ahead.

By focussing upon long-range objectives of that and related sorts, for the society as a whole, we may construct a way of thinking ahead about the economy, a generation or more ahead, and in its totality. It is against that background, in long-



*The space program, as a science-driver for the world economy, forces society to think ahead about the economy, a generation or more ahead, and in its totality. Here, astronaut James S. Voss, cosmonaut Yuri V. Usachev, and astronaut Susan J. Helms, aboard the International Space Station, March 10, 2001.*

range foresight, that the small, but cumulatively powerful improvements in productivity and process can be defined with sufficient approximation to suggest clear decisions.

Thus, the primary estimate of productivity, is the effect of any particular, local or other change, on the productivity of the economy considered as an indivisible whole. This could be described as tracing the effect of a qualitative perturbation in some local aspect of the whole economy, on the productivity of the economy as a whole. That, broadly, points to the kinds of calculations which must be considered of primary significance in studying variations in characteristic productivity in an economy considered as a whole.

For example, there are famous studies of a remarkable change in U.S. manufacturing productivity, which appeared as a consequence of increasing use of electric motors attached to particular machines, to replace the belt-driven factory-wide systems which had been general practice earlier. That is merely typical of the effect of introducing a new technology in some local aspect of production, and tracing the ripples caused by that upon the system as a whole. The most important fact to be adduced, is: why are such effects produced? How much, may be important, but it is secondary.

*Often, an obsessive fascination with the nitty-gritty, is the obstacle, the tragic folly, which blocks the pathway to the sublime.*

It should be stated, and emphasized at this point, that the results of the foregoing kinds of comparisons will not necessarily correspond to what might be estimated if the measurement of effects were made in terms of price-determined purchasing power of inputs and outputs at a locality, such as an individual firm, or particular industry, such as one defined

by the U.S. census of manufactures. It were often likely that the correlation might even be negative.

In summary of this point, our primary estimate must be the global, long-term effect of local changes on the productivity of the economy considered as an indivisible whole process. This primary estimate, is then treated as a change which is characteristic of that state of the economy as a whole; that estimated characteristic is then compared, or, better said, contrasted with the local estimate of change in productivity at the point at which the ripple was generated. Here, is the point on which calculations should be focussed. It is the difference between the apparent local values of change in productivity, and the related characteristic change in the economy as a whole, especially the major, long-range changes, which is the most interesting point of focus of our attention.

At this point, switch focus, from the action of the hand and senses, to the cognitive action of the mind. Look at this through the prism of a Classical humanist standard of general and higher education.

### **A Science-Driver Economy**

What I have referenced in various ways, at various points in this report, and in earlier locations, is the concept of a cognitive “simultaneity of eternity.” On this account, I have emphasized two points of policy which must be emphasized in defining a future recovery from the presently ongoing, global economic catastrophe. These are, a shift to a Classical humanist mode of education, at all levels of education, and a new quality of emphasis on universities as the focal point of science-driver policy for direction of the economy as a whole. The implications of the notion of potential relative popula-

tion-density, as application to past, present, and future, fall into place more easily when these two points of policy are made the point of reference.

To that purpose, I turn now to the subject of my educational policy, and, after that, the way in which such an educational policy flows, naturally, into my conception of introducing a science-driver form of economy as a natural next step in the development of what Hamilton, the Careys, and List named “The American System of political-economy.”

In earlier locations, I have used the image of a contemporary child re-experiencing an act of original discovery of a universal physical principle by the ancient Archimedes. I have emphasized, that every child should be educated in that way, and no other. The object of education must be, primarily, that the pupil should accumulate a memory of having re-experienced the actual cognitive act of original discovery of a universal physical principle made by persons who, for example, are today, chiefly, long deceased, even back many thousands of years.

In the act of re-experiencing such an original discovery of universal principle, there is a wonderful change from the effects produced by standard instruction in learning in general and higher education today. The change makes education *human*, for a change.

The keys to understanding this difference, are, in summary, the following.

First, the act of cognition through which a successful hypothesis is generated, is a mental process which is perfectly opaque to the sense-perceptual apparatus of the external observer. Therefore, the most important of all social acts, are those transactions through which a valid hypothesis and its validation as a universal physical principle, is replicated as a cognitive act provoked in the sovereign cognitive powers of another person. It is the power to generate and transmit, so, verifiable discoveries of universal physical principle, which is the absolute difference between a human being and all other living creatures. Therefore, we should educate our children for what they are, human beings, rather than the monkeys, which programs in mere learning imply those children to be.

This cognitive form of social relationship is not limited to relations with living persons. In the case of the actual reenactment of an original discovery of a universal physical principle, originally made by a long-deceased discoverer, the student has established an active relationship with that deceased person which is of the same degree of social intimacy, and distinctively human character, as with any living person. The reenactment of a cognitive act of discovery performed by a long-deceased person, produces a living memory of that reenactment within the mind of the (for example) student.

Indeed, I have reminded my readers many times, Raphael Sanzio portrays a crucial principle of the human education of human beings, in his famous *The School of Athens*. The mind of the person who has acquired knowledge through a cognitive relationship with persons both living and deceased, has the living memory of that person, as represented by the

relevant cognitive act or acts of discovery, present as a virtual living personality within his or her own mind. All even approximately competent education produces precisely that sort of effect, or a fair approximation of it in the mind of the student.

Within the conscience of the person so educated, the voices of many from among the greatest known scientists, artists, and statesmen of the past are heard as living voices in the mind. This is the jury to which the discoverer appeals, even when he disagrees with many among those authorities from the past. He is self-obliged to present them compelling arguments, which should win them to accept the discoverer’s overturning of what they had adopted and defended in their time.

For that and related reasons, a truly human relationship is based upon that quality of cognitive relationship. This point is the pervasive burden of Plato’s Socratic dialogues, for example.

This cognitive quality of relationship, is also the proper definition of *sanity*, in contrast to the insanity represented by ideologies such as “free trade” and “shareholder value.” The habit of thinking cognitively, of seeking out and challenging the paradoxes lurking within popular opinion, for example, is the standard of sanity of both individuals and societies.

Therefore, the policy must be that a truth-seeking Classical humanist mode of public and higher education, as so indicated, must be the only tolerated standard of education in the U.S.A., in particular, from henceforth.

Examine an additional implication of what I have just stated.

Man’s power in and over the universe, stems entirely from those cognitive processes by means of which discoveries of universal physical principle are transmitted, from past to present, and future. Therefore, if we define the university as the pinnacle of a system of universal education premised upon Classical humanist principles, the advanced and other research functions properly situated in such a university system, provide the most appropriate driver for both the world’s economy and for the crafting of those long-range objectives around which today’s physical-economic policies are defined.

The notable benefits of such a policy, are not merely technical, but also moral and psychotherapeutic. The development of a person’s sense of a close personal sort of cognitive relationship, to not only some of the greatest intellects of humanity’s past, but an impassioned regard for those past contributions which have yet to be fully realized, if realized at all, motivates us to see in our selves the opportunity to change the outcome of past history, by rescuing for the present and future, that which might have been lost forever without our current intervention.

That view of our cognitive relationship to great personalities of the past, informs our view of ourselves, as the image of our living self might be reflected back to us today, from those observing us in the future. Similarly, in a related way, we must be impassioned to ensure that the future does not

make the terrible mistakes we know of the past and our present time.

In our minds, so informed and developed, the past, present, and future have an historic order in respect to each other, but, in our minds, those whose acts of cognitive discovery we have relived live within us, as if they were our moral contemporaries. Thus, it is said, we become privileged, through the redemptive process of cognition, to live forever, with such companions, within an eternal moment, called sometimes “the simultaneity of eternity.”

What I have described so, to that point, in this report thus far, typifies what should be the mental outlook of the qualified long-range forecaster. We, who walk in that profession, think in terms of a simultaneity of eternity’s reach in the future. That is long-range thinking; that is the essence of competent long-range economic forecasting.

There are, admittedly, important obstacles to success of such a venture. I addressed some typical problems of that time in addressing the problems posed by the cult of Isaac Newton, above.

The crucial principle of physical economy which defines a science-driver economy, is that the increase of mankind’s potential relative population-density within the universe, depends essentially on the discovery and socialization of universal physical principles. The university-tipped Classical humanist form of educational system, thus typifies the form of practice by a society which realizes both aspects of the principle of universal human progress. The Classical humanist method develops the ability of the individual mind to recognize ontological paradoxes and effect relevant, verifiable discoveries of universal physical principle. The same method socializes both the process of discovery, and the discoverer as both student and scientist.

The universities of educational systems of that intention, each and all modelled implicitly on the method of knowledge exhibited in Plato’s Socratic dialogues, should serve as the pinnacle of science. That should drive the economy. In brief, that proceeds by the following steps.

In competent programs of education in what is conventionally termed “physical science,” in schools and universities, there is great emphasis on two sets of experiments. The first, are called pedagogical experiments, through aid of which the student reenacts the crucial and other discoveries of the past, in a Classical humanist, which is to say, “Socratic” way. This accumulation of pedagogical experimental work, prepares the student’s mind for discovering and testing hypotheses.

All of the historical knowledge and skills represented by pedagogical instruction and experiments, is then marshalled to serve as a point of departure into the previously unknown. The pivot on which the success of a science-driver program hangs, is fundamental, experimentally oriented research into discovery of new universal physical principles. This success requires intense concentration on a crucial feature of the design of proof-of-principle experiments, a feature

to which I have already referred, above.

In any successful proof-of-principle experiment, there are elements of the design of the experiment which are in specific correspondence to the principle at issue in the test in the chosen medium. Thus, the success of that experiment identifies those distinctive elements of the experimental design as the appropriate keys to the application of that principle in the designs of products and productive processes.

The bridge between the university-centered programs of fundamental research and the productive economy, is provided, usually, by the very type of machine-tool-design engineering which the current fad of “benchmarking” has proposed to eradicate, *that in the interest of promoting both the evils of out-sourcing, and product-quality failures in performance!* The type of machine-tool-design practice consistent with proof-of-principle experiment, is the bridge between so-called “pure science” and production of qualitatively improved kinds of products and processes.

On the condition, that the indicated principles of educational policy are in force, then society’s priority ought to be that of increasing the ration of the total population being so educated, and employed in the indicated categories of research and of product and process design. This should be reflected in the ratios of composition of the labor-force in each agro-industrial category of production and science-based services.

The best medical system, which the U.S. was working toward improving under the post-World War II Hill-Burton law, was the emphasis on full-service public teaching hospitals, including those associated with universities. These were but one aspect of the total capacity for developing and delivering medical and related benefits, but they were exemplary, and crucial in the respect that their patients were selected on the basis of the patients’ needs, rather than any different consideration. Such hospitals typify the principle of the science-driver approach I have summarized immediately above.

For related reasons, I continue to propose mission-oriented, pioneering, science-driver programs, as typified by the Manhattan Project, by the development of the space program, and by my own design for what President Reagan named a “Strategic Defense Initiative.” A large-scale, long-term mission, assigned the task of making the seemingly impossible real, expresses the principle of science, and of human progress generally, in a way nothing else could do.

The revolutionary impact of war-time and related science-driver programs, and their expression in new qualities of technologies, products, and processes, happened to lie largely in the military or related functions of government, because such scientific and technological achievements were unlikely to occur in any other way. The massive concentration of power, by government, on areas of breakthrough beyond the capacity of any private enterprise, is the only way in which the transition to a science-driver economy is likely to emerge.

At a somewhat later point, the science-driver approach should become the habit of society. The task before us now,

is to bring that habit into being.

Nothing I have proposed on this account takes us outside the lessons of the experience of science and economy until now. Once the institution of the sovereign nation-state based on the principle of what was called the “general welfare” or “common good” was brought into being, in modern history, the science-driver economy was always the implied direction which nations such as the U.S. should have taken.

Today, as is often the case in history, the most massive economic crisis this planet has known in historic times creates, ironically, the peculiar set of circumstances, a relatively unique opportunity to make that transition. This transition, if it occurs, will be made, not because it is attractive in its results, but because there is no other possibility for avoiding the slide of this planet into a now threatened new Dark Age. Only when a people is motivated by an awesome need for sudden and dramatic remedies for monstrous crises, have nations so far, adopted and sustained that sense of mission such undertakings require.

Given the scale of the present human population, and the need to increase its potential relative population-density rapidly and massively, no solution for mankind exists, except as the nations mobilize around great projects such as the Eurasian Land-Bridge. That project illustrates the role of great revisions in educational and other economic policies, which are needed to transform the conditions of life of the populations of Asia and Africa, for example to the state of affairs in which a now-looming, awesome demographic-economic collapse does not occur.

I fear, that, as usual, nations will not find the will to do good, until the implications of not doing good terrifies them into the state of mind in which the masses of people look up to the heavens, and pray: “Dear God, we, your children, have seen Your terrible signs. Please tell us what you expect us to do.”

## Free Will And Credit

The distinctive quality of the human species, which places it outside and above all other forms of life, is its power of what is called “free will.” However, as we should have observed, “free” is not necessarily good. The word “free” must therefore be defined properly, not as arbitrary choice, but as the freedom both to discover the truth, and to change society to bring it into conformity with truth. It must be made clear, that the word “freedom” is a disgusting, wicked thing, unless it is understood in the sense of seeking truth and acting accordingly, as the greatest discoveries of universal physical principle, including the best examples of Classical artistic composition, best typify true freedom. Freedom is cognition, the quality which sets man apart from, and above the beasts.

Freedom means, of course, the abolition of slavery and serfdom; it also means the abolition of prejudices and practices which tend to condone slavery or serfdom. It means that and similar things. However, all of those good things could

not be secured, except as we define “freedom” to signify innovations of practice premised upon the discovery of valid universal physical principles.

The word “freedom” is often, usually, abused. It is abused, in large part, because most people today simply do not know what it is. It is like the famous cartoon figure, “Kilroy,” whose naughty twin was called “Schmoe,” which appeared on broken walls and other such places, around the world, wherever U.S. military personnel were active during World War II. The name was widely recognized, and, like the word “freedom,” on nearly everyone’s lips; but, apparently, no one ever discovered who “Kilroy” was (although there were widespread, but varying suspicions as to the identity of “Schmoe”).

“Freedom” is a term, which has a definite, properly preferred meaning. That meaning is, like a valid principle of physical science, an object which has a very efficient existence, but is not an object of sense-perception as such. It means, in practice, the policy of freeing mankind from presently relatively debased circumstances, and modes of behavior, through dedication to the discovery and application of truthful, valid universal physical principles. It means, in that sense, the freeing of persons from the cruel shackles of their own ignorance.

This desire for true freedom, can not exist without a corresponding, appropriate passion, an impassioned intention. In all known history thus far, this quality of intention has usually been found only among a relatively minuscule number of individuals, the terribly few who have qualified as true leaders of their fellow human beings. The essential function which those leaders perform, which defines them as leaders, or not, is the ability, under conditions of crisis, to lead their fellow-man safely out of bad places, such as a fire in a crowded theater.

There is nothing properly mysterious in such qualities of leadership. Essentially, this is the quality portrayed in himself, by the great painter Raphael Sanzio, as in his *The School of Athens*. The leader for a time of crisis, is one who has located his or her sense of personal, historical identity in what I have described as “the simultaneity of eternity.”

The person who emerges as a true leader in time of crisis, such as the historic, and also the dramatic figure of France’s Jeanne d’Arc, is not quite the self-sacrificing character which the Romantic misrepresents such leaders to be. The quality of such leadership is the sense of one’s self, of the purpose of one’s existing in a specific time and place, as a mission for the sake of all past and future humanity. This is a quality of passion which includes the determination that that unrealized good of past heroes shall be enjoyed by future humanity, and that the future shall regard us now as worthy agents of humanity yet to become.

The consequent passion, is an impassioned sense of one’s own identity, as the Passion of Jesus Christ portrays this for the Christian, or as Plato’s *Phaedo* presents the immortality

of the soul of Socrates. No Romantic substitutes will do. The passion must be real, must be premised on a sense that one's life has an essential mission for all mankind past and yet to come, a mission which, in a time of crisis, has suddenly been made clear to the bearer of that quality rightly called leadership.

Among outstanding cases of leaders of that type, another expression of the same dedication, the same sense of personal historical identity, is met: to show humanity the pathway to a better future.

This quality of leadership appears in the guise of economics as the necessary use of public credit in a manner which horrifies those mean-spirited dragons and goblins known as "fiscal conservatives." This credit, is the use of the unique, constitutional, power of the sovereign nation-state republic, to maintain a monopoly of the issue and management of its currency, to manage its banking systems, and to incur long-term obligations for the purpose of expanding useful employment and building the foundations of growth, thus creating the benefits on which the future validity of that government-created credit depends.

Perhaps few recent developments have demonstrated this principle in a clearer way, than the combined effects of tight-fisted looting of the general welfare, in the name of fiscal conservatism, while looting the nation's economy into a state of wreckage by the combined effects of that conservatism and profligate, implicitly hyperinflationary expansion of private debt for nothing more substantial than the inflation of what are predominantly merely nominal forms of financial assets.

Look back approximately thirty-five years, when the U.S.A., largely thanks to the legacy of President Franklin Roosevelt, had a powerful economy which still worked. By the time fiscal conservative Richard Nixon had wrecked the world's monetary system, beginning mid-August 1971, the U.S. was already moving in the direction of becoming a "carpetbagger's economy"; the Carter Presidency ruined most of that which Nixon had not wrecked. Those changes of policies, during the recent thirty-odd years, have wrecked the economies and much else of the Americas and Europe, to say nothing of the monstrous crimes against, especially, sub-Saharan Africa. Most of this ruin was done through measures of "fiscal conservatism" which turned the U.S., in particular, away from its earlier greatest economic achievements, the successes which had never occurred except through the use of public credit to expand the physical economy, defend and raise the standard of living, promote the general welfare, and reach the objectives defined as a mission for the foreseeable future.



*President Franklin D. Roosevelt signs the Tennessee Valley Authority legislation, May 18, 1933. What Roosevelt did, in reorganizing a bankrupt economy and providing a sense of national mission, we can and must do, again, today.*

The financial system of the U.S.A., in particular, must now be put through drastic and early measures of bankruptcy reorganization. Trillions of U.S. dollars of nominal shareholder assets have already vanished down the proverbial rabbit-hole of follies such as the "new economy," and more will soon vanish as the vastly inflated real-estate bubble pops. The clone prince is dying, like the Dorian Gray of the Oscar Wilde fable.

Where then lies the security against which trillions of dollars' worth of new public credit might be issued, under these circumstances? That is not a moot-court question; either that credit is generated and issued in appropriate ways, or the present U.S. economy, which is in a far worse physical condition than that of 1932-1933, may simply disintegrate under continued, even draconic political efforts to impose fiscal austerity. Therefore, we must have the vast expansion of public credit, as the only means by which a return to real economic growth may occur. What then, shall be the security for that issuance of credit, especially under the given present circumstances?

When the clone prince dies, what shall we do?

Public credit, is credit in ourselves as a people. We can give ourselves credit, only if we are assured that we have adopted a mission, whose outcome must be the achievement against which we issue the credit to ourselves. President Franklin Roosevelt did that; we can, and must do it again. For that purpose, we require an adopted sense of national mission which is creditworthy. That can be done only through a concerted mustering of our national free will.

## Who Harbors Terrorist FARC Cartel? The ‘Grasso Factor’

by Gretchen Small

Without the political and economic support, open and covert, provided to the drug trade by international financier interests, the in-depth logistical and financial capabilities upon which global terrorism feeds for its existence could not be sustained. Efficiency in warfare, requires that support be broken.

The flagrant sponsorship of the largest cocaine cartel in the world and greatest narco-terrorist force in the Americas, the Revolutionary Armed Forces of Colombia (FARC), by

the financial interests of Wall Street and London, typifies the rot to be rooted out. Support for the FARC extends beyond merely using their money, but involves a project to integrate the FARC, as an organization, into globalization’s “democratic” structure internationally. Here is a summary chronology of this criminal scandal, further developed in the companion article.

**June 26, 1999:** New York Stock Exchange (NYSE) Chairman and Chief Executive Officer Richard Grasso kicked off the public campaign to legalize the FARC and its “consumer products,” cocaine and heroin, with a personal visit to the FARC-controlled area in the south of Colombia. The NYSE’s Vice President of International Relations, Alan Yves Morvan, and the NYSE’s head of security and protection, James Esposito, accompanied him.

Dick Grasso, a Vietnam War veteran and college dropout who advanced his way up from the NYSE’s listings department to the top, allegedly by means of his “marketing skills,” is touted as the man who created the “world equity market.” Elected president and chief operating officer of the NYSE in 1988, and chairman and CEO in June 1995, some call Grasso “the public face of the greatest bull market in U.S. history.” Grasso likes to say that bringing “world-class companies” from around the globe into the NYSE is his principal challenge.

In a June 29, 1999 press conference at the NYSE, Grasso hailed the FARC leadership as “extraordinary,” said they had discussed a “mutual exchange of capitals,” and announced that he had invited the FARC’s “Supreme Commander” and Reyes to “walk the trading floor with me” at the NYSE.

Grasso hailed his FARC pact as part of the stock exchange’s strategy of being “very aggressive in trying to pursue international markets and opportunities.” It was an “extraor-



*The much-acclaimed “leader of America’s recovery” Richard Grasso, New York Stock Exchange President, and his notorious embrace of FARC terrorist commandante Raúl Reyes, in 1999.*





Another U.S. financial power embraces the narco-terrorist FARC: America Online founder Jim Kimsey (third from right) and FARC commandante Manuel Marulanda (third from left) exchanged caps in the FARC zone, March 2000.

dinary experience, in the sense that the Comandante [Reyes] was trained as an engineer in the former Soviet Union. Very sophisticated, despite what the surface appearance may have been, in terms of his jungle fatigues and his M-16. And he knew a *lot* about investment and capital markets, and the need to stimulate outside capital coming to Colombia. Very interested in how Colombian companies could come to the U.S., and raise capital to be invested in the country.”

Grasso’s visit was by no means the first contact between the FARC and U.S. establishment envoys — State Department Andean Affairs desk officer Philip Chicola had met with Reyes in Costa Rica in December 1998. But, typical of Grasso’s general role as the “P.T. Barnum” for Wall Street’s more important players, Grasso’s trip was designed, in particular, to launch the media campaign for the FARC legalization project. The *Wall Street Journal* commented in an editorial note that same June 29, “Mr. [sic] Reyes . . . is profitable, he’s global and he’s strategically positioned. Stay tuned, the NYSE chairman is said to have offered the guerrilla a floor tour of the exchange. What’s next, an IPO?”

The gambit was, in fact, for something bigger. Grasso said that he hoped his visit “will mark the beginning of a new relationship between the FARC and the United States”; and despite his *pro forma* claim that his was a “private” initiative, he reported that he was briefed by U.S. Ambassador to Colombia Curtis Kammen, and he in turn briefed the ambassador upon returning.

The message delivered—that a pact with the FARC enjoyed “the interest and cooperation of the financial circles of the United States,” as one pro-FARC outlet put it—was a

warning to Colombians and U.S. officials who opposed the deal, that they would have to take on Wall Street, to take down the FARC.

**Jan. 22, 2000:** Grasso returned to Colombia, this time for a meeting in the Caribbean resort city of Cartagena with Colombian President Andrés Pastrana and his “Millennium Group” of advisers. Made up of “13 of the world’s leading financial and business heavyweights,” as Colombia’s media reported it, the Millennium Group’s task was to organize international support—and investments—for Pastrana’s “peace” plan with the FARC.

Attendees included America Online co-founder Jim Kimsey, Mitsubishi’s Minoru Makihara, former American Express CEO James Robinson, former President Sir George Bush’s business partner and former Canadian Prime Minister Brian Mulroney, Lorenzo Zambrano of Mexico’s Cemex, Ronnie Chan of Hong Kong’s Hang Lung Development Co., and Washington powerbroker Vernon Jordan. Violy McCausland, president of Violy, Byorum & Partners, and former partner of

World Bank President James D. Wolfensohn, put the group together. Kimsey served as its spokesman, telling the press afterwards that Pastrana had been assured of international support as long as he stuck to his policy of peace with the FARC, and economic austerity worked out with the International Monetary Fund (IMF).

**Jan. 27, 2000:** Pastrana’s National Planning director Mauricio Cárdenas announced that the government had the support of the IMF, in writing, for *unconditional and unrestricted* funding for “investments” to win the FARC, whose terror was worsening and intensifying, to the “peace process.”

**Feb. 1, 2000:** Seven *comandantes*—including Raúl Reyes and Simón Trinidad, a banker who joined the FARC’s leadership years ago (and whose sister-in-law, former Culture Minister Consuelo Araujo Noguera, was murdered by the FARC on Sept. 30, 2001)—took off for a 23-day, six-nation, all-expenses-paid tour of Europe. Accompanied by Colombian government officials and businessmen, the FARC leaders met with government ministers, parliament deputies, and leading organizations of European industry, commerce, and labor.

Secretary of State Madeleine Albright told the U.S. House of Representatives International Relations Committee on Feb. 16, that the FARC tour was “remarkable” and “very encouraging.” The FARC was on the State Department’s list of international terrorist groups at the time!

Official photographs of the meetings, published around the world, conveyed the message that it is acceptable for anyone to meet—and do business with—the FARC. Reyes summed up the tour’s impact: “The FARC has received de

facto recognition of belligerency status. . . .”

**March 4, 2000:** Jim Kimsey, the co-founder and chairman emeritus of America Online, and his sidekick, millionaire real estate investor Joseph E. Robert, Jr., paid a personal visit to the FARC in its Caguán redoubt. Their meeting lasted a good three hours, and included talks with FARC “Supreme Commander” Manuel Marulanda, alias “Sureshot.” At the end, Kimsey swapped baseball caps with Marulanda, giving him his AOL cap.

In a March 20 commentary published in the *Washington Times*, Kimsey and Roberts reported they had discussed “the new global economy” and potential U.S. investments with the FARC, and suggested the next step was for FARC leaders to come to the United States, to speak “directly to the U.S. Congress and to the American people. . . . [W]e do believe our leaders should listen to them.”

Council on Foreign Relations member Kimsey and his partner Robert, like Grasso, are among those business executives and speculators who made their millions (or billions) off the “New Economy” of the Information Age, and who see themselves as shaping a “new world order,” in their own interests—one that supplants the nation-state with corporatist power.

Kimsey, in particular, is plugged into the military and intelligence community. A Special Forces Ranger officer during the Vietnam War, Kimsey there served as assistant to the commanding general of Special Operations at the Military Assistance Command, responsible for making assessments of special operations. He left military service in 1970 to start a career as a stockbroker (a move which ran into difficulties in 1975 when the SEC banned him from any brokerage involvement for five years after he pled guilty to charges of stock manipulation). He kept his fingers in the military “pot.” Kimsey serves on the advisory board of the Joint Special Operations Forces Institute, and is a member of the “Tail to Tooth” Commission of Business Executives for National Security (BENS), which is involved in counter-terrorism projects.

**November 2000:** The Kimsey-Robert duo remained on the case, visiting Havana, for a seven-hour private dinner with Fidel Castro in which, explained Robert, they “explore[d] getting Castro’s support” for the Colombian jungle project they are developing.

**March 28, 2000:** Britain’s Foreign and Commonwealth Office Minister of State with responsibility for Latin America, John Battle, announced to the House of Commons that Prime Minister Tony Blair’s government “would welcome” a joint mission of the FARC and Colombian government such as just toured Europe, and has so informed the Colombian government.

**March 30, 2000:** A FARC communiqué called upon the government of the United States to legalize drug consumption, and for the U.S. Congress to send a delegation to “their” territory in southern Colombia, to tour the region, to dialogue with the FARC leaders first-hand.

# U.S. Still For Talking To Colombian Terrorists

by Valerie Rush

In his much-cited national address on Sept. 20, President George Bush announced his government’s commitment to carry out a war on terror “until every terrorist group of global reach has been found, stopped and defeated,” wherever it exists around the world. What about the Revolutionary Armed Forces of Colombia (FARC), right here in this hemisphere?

The FARC is on the State Department’s official list of terrorist groups, with which the U.S. government will have no dealings—supposedly. The FARC is so heavily involved in all aspects of the cocaine trade, that it is the world’s number-one drug cartel, controlling about two-thirds of the cocaine that enters the United States every year. It systematically perpetrates hideous crimes, including kidnapping and murdering civilians, and forcibly impressing thousands of children into guerrilla military service. And the FARC has already spread its narco-terrorist activities to neighboring Andean nations, and threatens the security of the United States itself.

And yet the U.S. State Department continues to *actively promote* the Colombian government’s criminal policy of so-called “peace negotiations” with the FARC, under which, three years ago, they were granted a vast “demilitarized zone” (DMZ) in the cocaine heartland of southern Colombia, and from which they today exercise de facto control over about half of the national territory.

## When Is Terrorism Not Terrorism?

The answer to this rather obvious, but most embarrassing, question, lies in what can be called “the Grasso factor.” This refers to the famous photograph of New York Stock Exchange President Richard Grasso embracing Raúl Reyes, the head of FARC finances, in the cocaine-producing DMZ of Colombia. What that photo merely typifies, Lyndon LaRouche and *EIR* have documented over decades: The FARC, *like all terrorist groups around the world*, are nothing but instruments of irregular warfare deployed by powerful financial groups in order to achieve their political goals.

This is as true in Afghanistan as it is in Colombia. The only serious war against narco-terrorism is one that begins by going after the “Grasso factor”—the powerful financial oligarchical interests—running the irregular warfare in each regional theater.

That, unfortunately, is not the way Washington is approaching the Sept. 11 terror attacks in this country; nor is it the way it is approaching Colombia’s FARC.

The Colombian case is again before the public eye, as

the Andrés Pastrana government in Colombia must decide in early October, whether to “renew” the DMZ, an area the size of Switzerland, that is under FARC control. A national debate on this issue is ongoing—Colombian style.

On Sept. 30, a former Colombian culture minister was kidnapped and assassinated by FARC narco-terrorists. This was followed two days later by the assassination of a Congressman and the attempted assassination of a prominent retired general.

Consuelo Araujo Noguera, 66, wife of current Prosecutor General Edgardo Maya, and who was Colombia’s Minister of Culture during the early part of Pastrana’s term, had been kidnapped a week earlier, along with more than 20 others, during a FARC highway blockade. When Army forces discovered the kidnapers’ trail, the terrorists abandoned all but the ex-minister and a female friend. Already quite ill and ravaged by her week-long ordeal, Araujo was unable to keep pace with her fleeing captors. They forced her to her knees, and shot her five times in the head and back. Her friend was thrown over a cliff, and discovered by Army troops several hours later, barely alive.

On Oct. 2, leftist Congressman Octavio Sarmiento was assassinated allegedly by paramilitary vigilantes, possibly in retribution for the Araujo murder. That same day, assassins believed tied to the FARC, shot retired Gen. Rafael Cifuentes in the head, but reports are that his condition is stable, and he

will survive. General Cifuentes, whose adult son was murdered by the FARC several years ago, is a former director of Colombia’s Military School and former commander of the Army II Brigade. He resigned his post under the Samper Pizano government (1994-1998) in protest against that narco-regime. General Cifuentes has since been politically and electorally active.

The majority of Colombians, horrified by these latest terrorist atrocities, is now demanding that Pastrana put an end to both the DMZ and the farcical “peace process,” which has served far too long as a cover for the mass buildup of narco-terrorist forces in Colombia, now spreading throughout the Andean region. Newspaper editors, congressmen, Presidential candidates, business and labor leaders, and the average person on the street are all screaming for the government to take off the gloves, allow the Army to do serious battle, and finally treat the FARC as the drug-trafficking terrorists they are.

But Pastrana will do nothing of the kind. He will extend the DMZ and the negotiation process, with the full backing of the State Department and Wall Street. President Pastrana has let it be known, that not only does he plan to renew the DMZ on Oct. 8, but he is also prepared to negotiate a “truce” with the FARC. It will, in effect: 1) prohibit Armed Forces deployment against the FARC *anywhere in the country*, through a six-month “bilateral cease-fire”; 2) give the narco-terrorists a power-sharing role in the government, by convoking a Constituent Assembly to rewrite Colombia’s Constitution; and 3) finance the FARC out of the government’s own coffers, during this “transitional period.”

The U.S. State Department has stuck firmly to its policy of support for Pastrana’s insane strategy of appeasement and capitulation. At an Oct. 1 press conference, spokesman Richard Boucher repeatedly declared the Bush Administration’s support for the Colombian “peace process.” He was asked, “Isn’t the DMZ being used as a sanctuary for terrorism, to establish links with other terrorist groups in the world, and being handled by a terrorist group, according to the United States?” Boucher said only, “I think those are all questions that President Pastrana will consider as he makes this decision.” Reporters rejoined, “You’re tiptoeing completely around the same kind of peace initiative in Afghanistan.”

### **A Serious National Defense**

With the news of the kidnapping and assassination of Araujo, the Colombian military deployed 10,000 strong to the perimeters of the DMZ, chomping at the bit to be allowed by Pastrana to enter the FARC sanctuary . . . to no avail. In fact, on a number of occasions this year, the military has dealt serious blows to the FARC, but has been restrained from carrying its campaigns through to conclusion—because of the “Grasso factor.”

In February, more than 3,000 Colombian troops were deployed to the FARC-dominated southeast jungle region near Colombia’s border with Brazilia and Venezuela, where “Op-

For previews and  
information on  
LaRouche publications:

## **Visit EIR's Internet Website!**

- Highlights of current issues of EIR
- Pieces by Lyndon LaRouche
- Every week: transcript and audio of the latest **EIR Talks** radio interview.

**<http://www.larouchepub.com>**

e-mail: **[larouche@larouchepub.com](mailto:larouche@larouchepub.com)**

FIGURE 1

**Colombia: The Narco-Terrorist War Theater**



1,200 heavily armed terrorists *out of the DMZ*, to join with another 1,000 guerrillas in Colombia's southeast jungles. Their objective was to decimate the Carijagua military base established in the area in the aftermath of "Operation Black Cat," lay waste to any intervening towns and villages, and reestablishing the crucial cocaine-trafficking corridor to Brazil that the February military operations had disrupted. This time, 6,000 Colombian soldiers, led by the highly trained Rapid Deployment Force, responded with "Operation August 7": They moved into the area, destroying a portion of the terrorist column, killing the FARC's number-two military chieftain, and forcing the FARC forces to disperse into the jungle, and from there return to their Pastrana-sanctioned DMZ.

But the Colombian military was unable to move sufficient ground troops into the jungle area, to be able to actually retake *and hold* the territory in question. In this campaign, as in many others, the Armed Forces have been limited to conducting an essentially aerial war on its own territory. Vastly under-funded and under-equipped, it is subjected to withering political attacks from the human rights non-governmental organizations (NGOs)—which are funded by the drug-legalization lobby (including the notorious George Soros). The Colombian Army is fighting an uphill battle. The anti-drug aid that the U.S. government today provides Colombia, under the so-called "Plan Colombia," is so limited, and has so many strings attached—e.g., it cannot be used to fight the FARC, because they are supposedly

eration Black Cat" was launched against the largest cocaine trafficking ring in South America (see map 1). Vast cocaine plantations, a dozen drug laboratories, and Brazil's biggest drug lord "Fernandinho Beira Mar," who had been living under the protection of the FARC, was uprooted and arrested.

It has been plausibly reported that real-time intelligence support from the United States contributed significantly to the Colombian Army's successes—indicating that not everyone in Washington is happy with the "Grasso factor." Said U.S. Southern Command chief General Pace, who observed the raids first hand, "The FARC and narco-trafficking are one and the same in this region."

Then in early August, the FARC deployed a column of

principally "terrorists" and not "drug runners"—that it is little more than a bad joke.

Yet some in Washington may be rethinking this losing policy in the aftermath of the Sept. 11 attacks. According to the Spanish-language Miami newspaper *El Nuevo Herald* of Oct. 1, Florida Democrat Sen. Bob Graham, chairman of the Senate Intelligence Committee, thinks that, with each passing day, the FARC more closely resembles Osama bin Laden's organization. Graham, until now a supporter of the State Department and Pastrana's policy of narco-negotiations, today believes that "the structures of the FARC, its sources of financing and even its objectives," coincide with those of Al-Qaeda, bin Laden's terrorist network.

# Putin: Attack Drug And Terror Infrastructure

by Rachel Douglas

On returning from his state visit to Germany, which focussed on the scope and terms of collaboration between Russia and the West in a post-Cold War world, Russian President Vladimir Putin opened up a new dimension of what the tasks of that collaboration ought to be: a serious war on drugs. That was the main agenda item of a meeting of Russia's Security Council on Sept. 28, chaired by Putin.

The Russian President discussed the fight against narcotics as inseparable from the question of terrorism. He promised Russia will take new initiatives against dope-linked financial flows, as well as the physical shipments—moves that have far-reaching international implications. He said that the situation with drug addiction in Russia is “acute,” and “we must respond to it professionally and as rapidly as possible.”

“This problem is extremely acute today, and not only in and of itself,” Putin told his Security Council. “It is directly connected with the success of the struggle against crime. . . . And, of course, it is very closely interwoven with topic number one in the world, the struggle against terrorism. The narco-business is one of the main sources of financing for terrorist groups and irregular military units.”

Putin reminded the Council that 80% of heroin on the world market comes from Afghanistan, much of it shipped through Russia, with Afghan guerrillas controlling the trafficking. In the very recent period, he said, “a particularly large quantity of narcotics coming in from Afghanistan has been seized. The dope dealers, attempting to warehouse what they have accumulated in huge quantities over many years—industrial-size quantities—are rushing across the border, to hide this from possible destruction.” He called for upgrading Russian border forces.

## Narco-Terrorism

Putin defined the problem of narco-terrorism: “Terrorism and narcotics are absolutely kindred phenomena. They have common roots and a similar destructive force. Terrorism, like the drug trade, has a highly ramified international network, and is transnational, beyond a doubt. . . . This illegal business produces superprofits, and ‘dirty’ monies are spent for ‘dirty’ purposes.”

Next, Putin reviewed the headlong spread of dope in Russia. Highly refined drugs have an ever-greater market share. In first place is Afghan heroin, which comprises 28% or more of the dope consumed in Russia. Drug consumption has

spread throughout the various social layers, especially in economically depressed regions, bringing with it a very rapid spread of HIV infection. Drug addiction hits younger people more than before, the average age of first-time users being 14 years old. Every fifth conscript into the Armed Forces has used narcotics.

Russia is not only an end-product consumer, but also a major transshipment corridor for dope. Putin said that the problem could not be stopped just by seizing narcotics. Rather, “It is time to revise the criteria for our work in this sector as a whole. We must put an effective barrier to all forms of penetration of narcotics into illegal circulation, destroy the infrastructure of the narco-networks, and eliminate demand. . . . Therefore our objective is to close off all channels for the proliferation of narcotics, both external and domestic.”

## The Money Flows

The Russian President turned to the question of dope finances: “An important subset of tasks has to do with eliminating the financial channels for the narco-business, which can be done not only by a fight against criminal elements, but also with an entire system of special measures. These include combatting the legalization of criminal incomes.”

Going after “the financial channels for the narco-business”—as readers of *EIR* know from our dossiers on “Dope, Inc.” over the past two and a half decades—leads into the thick of the Anglo-American-centered world financial system. Really cleaning up the drug money business throughout Eurasia, would certainly be consistent with the vision of a continent free of the “clash of civilizations,” as conveyed by Putin in his Sept. 25 speech to the German Bundestag (Parliament). Such efforts are sure to encounter vicious resistance, not only from on-the-ground narco-traffickers, but from ostensibly respectable financiers and strategists in London and elsewhere, including Moscow, who have their uses for the dope trade, as they do for terrorism.

Russian officials are speaking more and more plainly about finding and holding accountable the sponsors of transnational terrorist units. At a press conference on Oct. 2, Putin's press spokesman Sergei Yastrzhembsky reviewed the situation in Chechnya, links between Chechnya and terrorist camps in Afghanistan, and international counterterror efforts. While stressing the current, unprecedented levels of Russian intelligence-sharing with the United States and European countries, Yastrzhembsky also denounced the harboring of terrorists in Britain. He said that Russia had previously provided names of specific organizations operating in London, among the 100-some foreign organizations funding the Chechen insurgents, but that no actions had been taken.

Yastrzhembsky hailed UN Security Council resolution No. 1373, adopted on Sept. 19, which obliges member-states to take measures against terrorist activities on their territories. Russia has signalled a desire to apply the same approach to the dope trade.

## When U.S. Joint Chiefs Planned Terror Attacks On America

by Edward Spannaus

According to documents that were intended to have been destroyed almost 40 years ago, top levels of the U.S. military proposed carrying out acts of terrorism against the United States in the early 1960s, in order to drag the United States into a war against Cuba.

These documents take on added significance in light of the Sept. 11 attacks on the World Trade Center and Pentagon, which were clearly intended, among other things, to drag the United States into a “Clash of Civilizations” war in the Middle East. Lyndon LaRouche has stressed, these attacks could not have been carried out without complicity from rogue elements in military/security circles inside the United States.

### Operation Northwoods

The first comprehensive published account of the 1962 documents, is contained in James Bamford’s book on the National Security Agency, *Body of Secrets: Anatomy of the Ultra-Secret National Security Agency*, released in late Spring of this year. Bamford concluded that the Joint Chiefs of Staff “proposed launching a secret and bloody war of terrorism against their own country in order to trick the American public into supporting an ill-conceived war they intended to launch against Cuba.”

Bamford’s account is based on documents which were ordered declassified by the Assassination Records Review Board, and subsequently released by the National Archives within the past few years. *EIR* has obtained the relevant documents and has independently reviewed them, and we can confirm that there is no exaggeration in Bamford’s description of these documents as containing proposals for U.S. military agencies to carry out terrorist actions against the United States and attacks on U.S. military facilities.

The time period in question, Winter-Spring of 1962, is bounded by the CIA’s failed Bay of Pigs invasion of April 1961 — an operation which had been set into motion under the

previous Eisenhower Administration — and the Cuba Missile Crisis of October 1962.

The terrorism plan was called “Operation Northwoods,” and was drawn up after President John F. Kennedy had shifted responsibility for dealing with Cuba, in late 1961, from the CIA to the Department of Defense (DOD), in the aftermath of the Bay of Pigs. The overall Pentagon project was known as “Operation Mongoose,” and was the responsibility of Edward Lansdale (a CIA man who was Deputy Director of the Pentagon’s Office of Special Operations at the time), and the Chairman of the Joint Chiefs of Staff (JSC), Gen. Lyman Lemnitzer, an Eisenhower Administration holdover.

The military planners led by Lemnitzer wanted to launch a full-scale invasion of Cuba to overthrow Castro — and perhaps, as well, they were anxious to show that they could succeed where the CIA had failed. Lemnitzer and others were also extremely distrustful of the new administration — especially after the Bay of Pigs, in which there were allegations that President Kennedy had refused to provide air support at the last minute (although it has since been documented that this was not Kennedy’s decision). The top military brass were accusing the Kennedy Administration of “going soft” on Castro, and their plans for a “pretext” operation to justify an attack on Cuba must be seen in this light.

### Pretexts For Military Invasion

The planning culminated in a series of memoranda and recommendations which were addressed in their final form by Lemnitzer to Secretary of Defense Robert McNamara, on March 13, 1962 — although it is not certain McNamara ever received them. (Last April, the *Baltimore Sun* quoted McNamara saying, “I never heard of it. I can’t believe the Chiefs were talking about or engaged in what I would call CIA-type operations.”)

Lemnitzer’s covering memorandum states that the Joint



*Top “smoking gun”:* Gen. Lyman L. Lemnitzer, later NATO Supreme Allied Commander, in 1962 oversaw Armed Forces schemes to carry out acts of deadly terrorism and “irregular warfare”—against the population of the United States.

Chiefs of Staff “have considered” an attached memorandum, which is a “description of pretexts which would provide justification for military intervention in Cuba.” He says that he assumed “that a single agency will be given primary responsibility for developing military and para-military aspects of the basic plan,” and he recommends that this responsibility be assigned to the Joint Chiefs.

The attached memorandum, entitled “Justification for U.S. Military Intervention in Cuba,” says that it is assumed that a political decision for a U.S. military intervention “will result from a period of heightened U.S.-Cuban tensions which place the United States in the position of suffering justifiable grievances.” World opinion and the United Nations “should be favorably affected by developing the image of the Cuban government as rash and irresponsible, and as an alarming and unpredictable threat to the peace of the Western Hemisphere.”

The proposed pretext actions should take place within the next few months, while it is still likely that the Soviet Union would not intervene, the memorandum declares, noting that there is “as of yet no bilateral mutual support agreement binding the U.S.S.R. to the defense of Cuba,” that Cuba is not yet a member of the Warsaw Pact, and that the Soviets have not yet established major bases in Cuba.

What then follows, is a series of proposals for actions which would be used to provide the justification for U.S. military intervention.

### ‘Blow Up A Ship . . .’

The first proposal is for “a series of well-coordinated incidents” to take place in and around the U.S. Navy base at Guantanamo Bay, Cuba; these were to include having friendly Cubans dress in Cuban military uniforms to start riots at the base, blow up ammunition inside the base, to start fires, to burn aircraft on the air base, to sabotage a ship in the harbor, and to sink a ship near the harbor entrance.

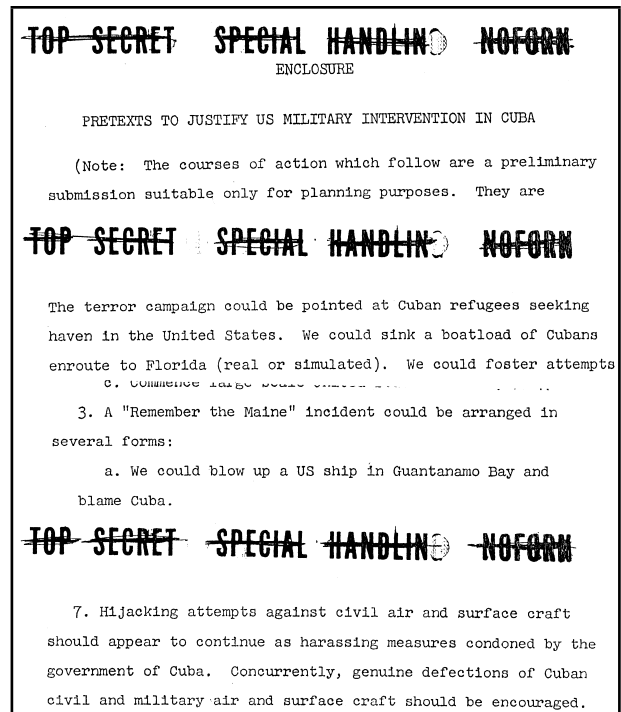

*The murderous acts some officers considered, as “pretexts to justify” U.S. invasion of Cuba.*

That was just the start. The next proposal elaborated: “A ‘Remember the *Maine*’ incident could be arranged. . . . We could blow up a U.S. ship in Guantanamo Bay and blame Cuba,” or blow up a drone ship in Cuban waters. The memorandum coldly predicted: “Casualty lists in U.S. newspapers would cause a helpful wave of national indignation.”

The memorandum continues:

“We could develop a Communist Cuba terror campaign in the Miami area, in other Florida cities and even in Washington. The terror campaign could be pointed at Cuban refugees seeking haven in the United States. We could sink a boatload of Cubans en route to Florida (real or simulated). We could foster attempts on the lives of Cuban refugees in the United States. . . .”

“Exploding a few plastic bombs in carefully chosen spots, the arrests of Cuban agents and the release of prepared documents also would be helpful. . . .”

Among other actions proposed were to use fake Soviet MiG aircraft to harass civil aircraft, to attack surface shipping, and to destroy U.S. military drone aircraft. “Hijacking attempts against civil air and surface craft” were also suggested, and then—the most elaborated plan of all—to simulate the shooting down of a chartered civil airliner in Cuban airspace.

President Kennedy rejected the plan, and Lemnitzer directed that all the pertinent documents be destroyed. Nevertheless, some of the documents did survive, although hidden by heavy classification for decades.

To the astute reader, the potential parallels with recent events should be chilling.



# Temple Mount Madmen Go For Armageddon

by Scott Thompson

Under intense international pressure, Israel's Sharon government again stopped the Temple Mount and Land of Israel Faithful (TMLIF) fanatics from igniting all-out religious war on Oct. 4. TMLIF tried to lay and anoint two cornerstones for the Third Temple of Solomon on Jerusalem's al-Haram al-Sharif ("Temple Mount"). They subsequently attempted to enter the Mount without the cornerstones, near the Western "Wailing Wall," but Israeli authorities repelled them a second time.

This marks the second time within a year that the TMLIF fanatics, whose titular leader is Gershon Salomon, have narrowly missed creating a sure-fire war provocation at al-Haram al-Sharif. In present circumstances, the "Third Temple" crusade on al-Haram al-Sharif, publicly drawing extreme Zionists together with much larger numbers of "Christian fundamentalists," might be the spark that ignites the Middle East tinderbox into a new Thirty Years War, and the epicenter of a "clash of civilizations"—the goal of powerful individuals within the Anglo-American Establishment, whom *EIR* has previously documented support this effort.

Sources within the TMLIF, and at the *Jerusalem Post*, reported that simultaneously with the cornerstone laying attempt, the International Christian Embassy in Jerusalem—staged its international march, which this year numbered some 4,000 because a large number of Christian fundamentalists turned out. Originally, only a few hundred had been expected. But many Christian fundamentalists have become convinced that the Sept. 11 attentat within the United States marked the start of the "End Times" as prophesied within the Book of Revelation.

## Threats Against Bush, Arafat

In an Oct. 3 interview with *EIR*, Salomon was asked whether it were true that an Israeli court had forbidden the TMLIF from carrying out their ceremony; Salomon denied he needed a court's permission, saying that it was a matter of what the Israeli authorities would permit.

Asked about Foreign Minister Shimon Peres efforts at a peace settlement, Salomon said, "He is a big danger for the security of Israel. . . . He meets again and again with Arafat, which is a terrible, sinful thing, since Arafat is like Satan." And, after the meetings, "Peres leads Sharon along, since Peres will not give up the Oslo Accords, and then there is more terrorism against the Israeli people."

Significantly, Salomon said that only in the Israeli De-

fense Forces was there the heart "to combat Satan's terrorists," and he agreed that this tendency was represented by Israeli Army Deputy Chief of Staff Moshe Yahalon. Foreign Minister Peres, in an interview with the Sept. 30 issue of *Yedioth Aharonoth*, had identified Yahalon as among IDF advocating the assassination of Palestinian Authority President Yasser Arafat.

Asked if he was disappointed with Sharon, Salomon first said: "Your President Bush yesterday [Oct. 2] said that he supports a Palestinian state. He will be punished like President Clinton. He will not be re-elected. God will shame him like President Clinton." Salomon added that he "is very, very disappointed with General Sharon." Salomon said that Sharon had been elected with a 65% majority, but he "is following the policies" of his immediate predecessor, former Labor Party Prime Minister Ehud Barak, by bringing the Labor Party into his coalition government.

At the end of the interview, Salomon interjected yet another potential threat against President George Bush, saying, "The focus of all the branches of terrorism in the world is Yasser Arafat. Bush made a pact with the leader of all the world's terrorists, for which God will punish him. Any war against terrorism must start with Arafat."

## Made In The U.S.A.

On Oct. 1, Salomon's U.S.-born executive secretary told *EIR* that Salomon had been "inspired" to undertake this latest provocation while in the United States, on a fundraising and "End Times" speaking tour that ended Sept. 15. Salomon, she said, got both the idea and the funding in the United States, for the plan to lay the two cornerstones, and to have them and the golden altar and vessels anointed by priests of the fanatic Jewish cult Ateret Cohanim, who practice animal sacrifice.

Salomon visited Texas, Colorado, Georgia, Missouri, Florida, New York, and Canada's British Columbia. In Virginia, he appeared with Christian fundamentalist "Diamond Pat" Robertson on his radio and TV broadcast "700 Club." Salomon was in New York on Sept. 11, preparing to return to Israel, when the planes hit, and was delayed four days, where he set to work on the project.

In Florida, according to the secretary, Salomon had a private meeting with Temple Mount money bags, Irving Moskowitz, who made his fortune through bingo parlors and other forms of gambling. Not only did Moskowitz fund highly provocative tunneling under al-Haram al-Sharif; he gave a large contribution to Sharon immediately before Sharon's visit, with 200 bodyguards to the top of the Mount on Sept. 28, 2000, which triggered the current Palestinian "Al Aqsa Intifada." While it is not known precisely whether Moskowitz is a member of the "Mega Group," which supplanted the "Billionaires Club," and which is believed to have controlled convicted Israeli spy Jonathan Pollard, he is certainly a "Megabucks" asset of that group, which *EIR*'s Jeffrey Steinberg exposed in the Aug. 31, 2001 issue.

In his newsletter for September-October 2001, *World of*

*the Bible News & Views*—in an article entitled “Will Israel Unleash The Dogs Of War?” Salomon’s close ally, fundamentalist leader Dr. Randall Price calls on Israel to engage in a general war. Dr. Price is also associated closely with former British military intelligence asset Stanley Goldfoot, who is tied to Jewish terrorist organizations associated with the late Rabbi Meir Kahane. Writes Price: “With all prospects for peace exhausted, with no common ground left for the Israelis and the Palestinians to negotiate their conflicted claims, and the nature of Islam programmed for *jihad* can there be any recourse for these peoples but to wage war? . . . A call for such a widespread end to Israel’s conflicts in the region has been voiced by Martin Sherman, a political scientist at Tel Aviv University, who served seven years in Israel’s defense establishment, who said: ‘It is time for this embattled nation to arise, to cry “havoc” and let slip the dogs of war.’ ”

---

## Interview: Andy Jacobs, Jr.

---

# Some Background To Pat Robertson’s Crusade

*Rep. Andy Jacobs was a Democratic Congressman from Indiana for 30 years, retiring in 1997. He and Rep. Pete McCloskey (R-Calif.) were sued for libel by televangelist Pat Robertson in 1988. He was interviewed for EIR by Nina Ogden in late September, to throw light on Robertson’s current crusade for war “against 1 billion Muslims.” On Sept. 18, at the 700 Club, Robertson had said that the terrorist attack of Sept. 11 had happened because America was so steeped in sin, that God had lifted his protection from it; he called for the United States to eliminate seven Muslim countries.*

**EIR:** You were a Democratic Congressman from Indiana and Pete McCloskey a Republican Congressman from California, when Pat Robertson sued you both for \$35 million for libel.

**Jacobs:** It all started when Robertson announced that he would enter the Republican Presidential primaries in 1988. His platform seemed typical of the “religious wrong”: a truculent foreign policy and rank selfishness for a domestic policy. . . . One of the things he said was, “When I was fighting in Korea, I wasn’t able to be in business.” That pricked up my ears.

**EIR:** You had gone to Korea at 18, as a Marine.

**Jacobs:** Precisely. It pricked up my ears. The next time I heard about Robertson was from my friend and fellow Marine, Pete McCloskey. He told an amusing story about a rowdy, hard-drinking fellow Marine lieutenant who was on a

Korea-bound ship with him. Pete said this lieutenant was the son of a U.S. Senator from Virginia, Willis Robertson. The son, Pete said, bragged all the way to Kobe, Japan that his Senator-father was going to get him out of combat and that his listeners would just have to fight the reds without him. Sure enough, when they got to Kobe, a Marine personnel officer came aboard and took Pat Robertson and his best friend Ed Ganes, together with four other Marines . . . off the ship and stationed them in Otsu, Japan.

Ganes was the son of the chancellor of William and Mary College. Both Ganes and Robertson were part of the Virginia aristocracy. The conversation between Pete and me was brief and amusing, because Pete said Robertson had become a TV preacher, preaching sermons quite different from the Lord’s view about peacemakers as expressed in the Sermon on the Mount. The TV holy hustler was a “kill a commie for Christ” man, Pete said. But he hadn’t been a “kill a commie (and maybe get himself killed) for his country” man, when duty called.

When the holy video voice decided it was time to skip God and try his hand at Presidential politics, his war policy and contrasting war record seemed appropriate for public discussion. Sounded war wimpish to me.

I wrote a letter to Pete and his answer took six pages. He said another Marine officer told him that the Marines who went to Otsu, eventually went to Korea and into combat. All except the Senator’s son, that is—who had been assigned to the First Marine Division Headquarters, so far to the rear as to be much safer than in the average American city, in those peaceful domestic days. Pete wrote that one of the “decoys,” a Marine named John Gerhart, told him that Robertson became the Division Headquarters’ liquor officer. . . .

**EIR:** I understand the Evans and Novak column—

**Jacobs:** Yes, Robert Novak reached me and asked if it was true that Pete had sent me this letter and whether I would give him a copy of it. . . . When Pete okayed them printing the letter, I got a photocopy to Bob Novak the next day. The day after that, all heaven broke loose. The news of the contents of the letter began in the column and spread like wildfire through the entire media.

**EIR:** Why did Pat Robertson sue you and Pete McCloskey for libel when he knew the contents of the letter were true?

**Jacobs:** Robertson knew the truth of it, but in the manner of Sen. Joseph R. McCarthy of Wisconsin, he figured he had to file a libel case to pettifog the reality, until the key Republican primaries were over. He filed two suits, one against Pete as the originator of the alleged libel and the other against me as the publisher.

He wasn’t about to sue the *New York Times* or *Washington Post* or any other of the major papers that carried the story, or the major TV networks. His lawyers wanted to avoid deep pockets on the defendants’ side of the case. As Pete put it, Robertson’s people assumed that, with his castle, stables,

and Christian cash machine, he could romp over a quickly financially-exhausted Andy Jacobs and Pete McCloskey.

**EIR:** But he lost the suit anyway.

**Jacobs:** My long-standing friend, former U.S. Senator from Iowa, John Culver, recruited George Lehner from John's law firm—Arent, Fox. George was compensated partly by contributions from by-then-inactive Marines, who somehow preferred war hero McCloskey over war wimp Robertson. Then we had a secret weapon, my Dad.

**EIR:** Your father, Andy Jacobs, Sr., was elected to Congress in 1948, and was a lawyer.

**Jacobs:** Pat Robertson didn't know our secret weapon was my Dad. Robertson claimed to have personal conversations with God, one in which he talked the Almighty into changing the deadly course of a hurricane. During one of those conversations, he should have asked God if, in creating my father, He had created one of the best libel lawyers in America; God had. At the time, my Dad was 80 years old, but the scent of such a legal contest perked him up. Who said Robertson couldn't work miracles? . . .

We got a lot of evidence very quickly in the depositions. Marine lieutenants who were in that Fifth Draft ship, and who were now successful business and professional people, backed up Pete's story. But we couldn't nail down the liquor officer part. . . . Robertson's lawyers avoided discussion of the real issue by harping on the liquor officer story. Because of an investigative report published by the Richmond, Virginia *News Leader*—which nailed down the real issues in our favor—Robertson's lawyers needed a diversion from it.

The *News Leader* reporter examined the late Senator Robertson's papers in the archives at William and Mary College. And, sure enough, there were letters from the Senator to Gen. Lemuel Shepherd, commander of the Fleet Marine Force in the Pacific during the Korean War.

**EIR:** I remember when that was published.

**Jacobs:** It was pretty memorable. One letter from the Senator to the General thanked him for arranging that Pat "wouldn't have to go into combat until he had more training." That would be more training than any other Marines would get. Another letter from the Senator assured the parents of Pat's friend, Ed Ganes, that they needn't worry, because Pat and Ed were going to an "interesting and historic place in Japan." By the way, my Dad found out that the English translation of Otsu, that "interesting place," is, "demon disguised as priest." Who says God doesn't have a sense of humor?

I won my case after a motion for summary judgment. But summary judgment was not granted to Pete at that point because of the liquor officer question.

**EIR:** But you won that one too.

**Jacobs:** We won after I received a call from a retired English



*Listeners to Pat Robertson's current calls for a "crusade" against the Islamic world, and those concerned about their effects, should read Rep. Andy Jacobs' account of his own and Rep. Pete McCloskey's court fight with the televangelist-turned-candidate in 1988.*

professor from New Orleans. He wasn't calling to correct anyone's grammar, but because he had been Pat Robertson's tent-mate at First Division Headquarters. In his deposition, he said that not only was Pat the unofficial liquor officer, but that he was pleased to call himself the liquor officer. Robertson had the enviable assignment of flying to Japan as the courier of codes. While on these cushy missions, Robertson would pick up liquor and fetch it back to thirsty Marines at the Division Headquarters officers club. . . .

The professor testified that the Korean woman who cleaned the quarters he shared with Robertson, was a 19-year-old young girl who wanted nothing to do with the prostitution that some other women had fallen into. That's the one, he said, that Pat Robertson hit on. She was terrified, that when Robertson would chase her outside the tent and "pinch her," that other Koreans who saw the spectacle would assume she was a prostitute. The professor explained, "Prostitutes were dead meat with other Koreans when the Americans moved on." But obviously, as far as Robertson was concerned, that was her problem. . . . A few days after the New Orleans deposition, Robertson moved to dismiss his case against Pete. . . . It was said that the case had been filed on the advice of the ultra-conservative activist, Paul Weyrich. The theory was to fog over the facts during the Presidential primaries. When asked by the news media to comment on the dismissal of the case against him, Pete said of Robertson, "He's chickening out now just as he did 37 years ago."

---

# National News

---

## U.S. Stock Mutuals Continue Deep Drop

U.S. stock mutual funds suffered the worst quarterly performance since 1987, in the third quarter of 2001. According to preliminary data released in late September by Lipper Inc., which tracks mutual fund activity, the average diversified U.S. equity mutual fund—a mutual fund that invests in stocks—lost 19.6% of its value during the third quarter this year. In the fourth quarter of 1987, diversified equity mutual funds plunged by 21%.

The losses were across the board, with 99% of U.S. stock mutual funds experiencing losses. But two subsectors of the stock mutual fund business indicate the severity of what befell the \$3 trillion stock mutual fund sector:

- “Large-capitalization-value” mutual funds, that invest in companies that have a large capitalization, that is, whose stock value ranges between several billion and several hundred billion dollars. According to the Lipper Inc. report, the value of large-capitalization-value mutual funds was off 9.82% during the third quarter. That level of loss would wipe out all the gains registered by large-capitalization-value mutual funds for the last three years.

- Technology mutual funds, that invest in “technology” companies. These mutual funds have lost 23.4% of their value in the last four weeks of the third quarter, 40.3% of their value during the last quarter, and 73.6% of their value since March 2000 (paralleling the losses of the Nasdaq stock market).

Investors have started to panic, withdrawing, on a net basis, \$5.25 billion from U.S. stock mutual funds during August. Trimtabs.com, which tracks the flows into and out of mutual funds, projects that during September, investors withdrew a record net \$37.8 billion from stock mutual funds, nearly double the previous largest monthly level of withdrawals ever.

Lyndon LaRouche forecast that the stock bubble, especially that based on the New Economy, would melt down. Driven by the desire for a quick gain, the majority

of Americans didn’t listen, and now, millions of people who invested in such mutual funds have lost three-quarters of their investment.

---

## ‘Suspicious’ Stock Trades Being Probed

In the first week of October, the Securities and Exchange Commission (SEC) requested that brokerages and investment banks in the United States and Canada “search their records” for patterns of “unusual” stock trades in 38 companies between Aug. 27 and Sept. 11.

The patterns particularly identified are “put-option” orders, where investors bought the rights to sell stock at current prices, on a future date—that is, betting the stocks would drop on the sell-date, which would earn such investors a tidy bundle. The SEC investigation is probing put-options in airline and insurance company stocks, which plummeted after the Sept. 11 attacks. Reportedly, German and British regulatory authorities are investigating similar patterns. The companies that have been named are:

- Airlines: American and its parent company AMR, Continental, Delta, Northwest, Southwest, United and UAL, and USAirways.

- Insurance: AIG, Chubb, Axa, Cigna, CNA Financial, John Hancock, MetLife, and Royal & Sun Alliance.

- Defense/Aerospace: Boeing and Lockheed Martin.

- Some of Wall Street’s leading lights: Morgan Stanley, Lehman Brothers, Bank of America, March & McLennan, American Express, Bank of New York, Bank One, Bear Stearns, and Citigroup.

---

## NAPM: Manufacturing Drops For 14th Month

The National Association of Purchasing Managers (NAPM) reported on Oct. 1 that “economic activity in the manufacturing sector declined for the 14th consecutive

month in September.” In September, the NAPM manufacturing index fell to 47.0, from a level of 47.9 in August. The NAPM reports that an index “reading above 50% indicates that the manufacturing economy is generally expanding; below 50% indicates that it is generally contracting.”

The NAPM index of non-manufacturing business activity fell to a four-year low, to 45.5 in August from 48.9 in July.

---

## AFL-CIO Tallies Huge Layoffs Since Sept. 11

According to an Oct. 2 release from the AFL-CIO, nearly 200,000 layoffs have been announced just since Sept. 11, across all layers of economic activity from the Miami City Ballet and Los Angeles Society for the Prevention of Cruelty to Animals to American Airlines and Boeing and machine-tool maker Milacron. “In New York City alone,” says the release, citing figures from the Fiscal Policy Institute, “an estimated 108,500 jobs will have been lost within a month” of Sept. 11. “An estimated \$6.7 billion has been lost in wages and compensation there, with an estimated \$16.9 billion in total output lost.”

The release, which erroneously attributes all the layoffs to the Sept. 11 terror attacks, rather than the economic depression which the AFL-CIO has refused to acknowledge, tallies the lost jobs by sector, and notes which companies are filing for bankruptcy protection, or freezing wage increases, or whose CEOs will work without pay, etc.

Subtotals are as follows: transportation, 112,940; services, 21,446; manufacturing, 62,732; public sector, 1,020; retail, 950; agriculture, 150.

In a similar depression announcement, Nortel Networks communications giant announced plans on Oct. 2 to cut an additional 20,000 jobs, citing a third-quarter loss of \$3.6 billion. The largest maker of phone equipment, Nortel will now have 45,000 employees, less than half its workforce at the beginning of the year. As of July 1, the company had already announced 30,000 layoffs in the United States.

## Bush Aviation Security Measures Face Scrutiny

On Sept. 27, President George Bush, in a speech to airline workers in Chicago, announced measures to tighten security at the nation's airports. First, he called for tighter standards and Federal oversight of passenger and baggage screening. National Guard troops are to be deployed, at Federal government expense, to provide an immediate increase in security. Second, the number of sky marshals on board airliners will be increased "dramatically." Third, there will be \$500 million in new funding for stronger cockpit doors with secure locks so that "our pilots will always be in command of the airplanes."

House Minority Leader Richard Gephardt (D-Mo.), standing at Bush's side in Chicago, expressed strong support for the measures, but Democratic members of the House Transportation and Infrastructure Committee were less enthusiastic. James Oberstar (D-Minn.), the ranking member on that committee, complained that Bush's measures don't go far enough with respect to passenger screening. "Airlines carry out that responsibility, now, by contracting with security-providing companies on a low-bid basis, and those companies hire the screeners and pay them the minimum wage. The results are what you would expect: high turnover in the workforce, failure of the screening process to work effectively," he said.

Oberstar is advocating, not just higher standards and greater Federal supervision of passenger screening, but Federalizing that function entirely. "The most basic responsibility of government is to protect its citizens against acts of war that threaten safety and security," he said, and the airlines "are the front line" of the war against terrorism. Peter DeFazio (D-Ore.), ap-

pearing alongside Oberstar, called Bush's package "half a loaf," saying that while locking cockpit doors and putting sky marshals on board airlines are "great measures," the first line of defense is to stop hijackers and their weapons from getting on the plane in the first place. What Bush and the Republicans have to decide, he said, is "are they going to stand in the failing system of today . . . or are they going . . . to break some campaign promises about no new Federal employees . . . about no new taxes?"

## Ashcroft Pushing His Anti-Terrorism Bill

Attorney General John Ashcroft continued lobbying for his proposed anti-terrorism bill, despite criticism from both conservatives and liberals over civil liberties concerns. On CBS News' "Face the Nation" on Sept. 30, Ashcroft claimed that the tools that he is asking for would reduce the risk of more terrorist attacks, despite the fact that during hearings on Sept. 24-25, he couldn't give an answer when asked whether the measures he is asking for could have prevented the Sept. 11 attacks. Ashcroft made clear that he particularly wants the authority to indefinitely detain immigrants whose status is open to question.

Senate Judiciary Committee Chairman Pat Leahy (D-Vt.), on the same program, noted that there were objections to Ashcroft's package from both sides of the aisle, especially in the House, and he indicated he was looking for a bill that would gain bipartisan support. He suggested that some parts of Ashcroft's proposal, such as those dealing with roving wiretaps, could pass easily. However, on the detention provisions, he warned that "we are go-

ing to have to make sure that we have some kind of check and balance in there. We don't want to be like countries that we criticize," when American visitors are detained, often without being told why.

On the House side, Judiciary Committee Chairman James Sensenbrenner (R-Wisc.) and ranking member John Conyers (D-Mich.) have been working on a bipartisan compromise that would exclude some of the more egregious provisions, including those dealing with indefinite detention, and retain those dealing with roving wiretaps, tracking Internet communications, and those who knowingly harbor a suspected terrorist. The committee is to begin formal work on the bill on Oct. 3, but Ashcroft had already expressed disappointment with a similar Senate-crafted compromise.

## Congress, White House Reach Budget Agreement

On Sept. 28, press reports indicated that Congressional leaders and the White House were close to signing off on a deal to provide \$686 billion in discretionary spending for fiscal year 2002, about \$25 billion more than President Bush had asked for last January. This amount includes an \$18 billion boost in defense spending, \$4 billion additional for education, and \$3 billion for natural disaster recovery. However, these totals don't include the billions that will be spent as a result of the Sept. 11 attacks on the World Trade Center and the Pentagon. Already, \$40 billion has been approved for disaster recovery, security measures, and defense, and \$15 billion for the airlines.

Budget projections prior to Sept. 11 have mostly been tossed out the

window. During a Senate Budget Committee hearing on Oct. 2, Pete Domenici (R-N.M.) said that the budget surplus projection for fiscal year 2002 had been in excess of \$176 billion before Sept. 11, and is now already down to \$52 billion. He attributed this reduction to not only the spending increases, but also the reduction in growth.

However, while some members of infrastructure-oriented committees are putting forward legislation to increase investment in railroads and other physical infrastructure, budget balancers such as Domenici and Budget Committee Chairman Kent Conrad (D-N.D.) are proving that some things don't change. The central issue of the Oct. 2 hearing, which was convened to examine the economic outlook in the wake of the Sept. 11 attacks, was determined not by what is needed to recover from the attacks, but rather the long-term effect of whatever measures are taken on the Federal budget. Conrad was clear that whatever fiscal stimulus is adopted in the short term, "we must also couple that with fiscal discipline in the long term." He said, "We should do nothing that reduces our revenue base in the future, because that will have a feedback effect on interest rates, today."

## Senate Passes Defense Authorization Bill

On Oct. 2, the Senate overcame the logjam that had stalled the fiscal year 2002 Defense Authorization bill and passed it by a vote of 99-0. Majority Leader Tom Daschle (D-S.D.) had pulled the bill from the floor on Sept. 25, because of a lack of agreement on amendments. One of these was offered by James Inhofe (R-Okla.), attaching the House-passed energy bill to the

Defense bill. Inhofe argued that the energy bill was relevant because it was both a national security issue and a military readiness issue. He told the Senate on Sept. 21, "Energy will be critical if and when America engages in military action."

The Defense bill returned to the floor on Oct. 2, following days of negotiations involving Armed Services Committee Chairman Carl Levin (D-Mich.) and ranking member John Warner (R-Va.). The turning point came during a Republican conference meeting on Oct. 2, when Warner and other GOP backers of the bill urged Inhofe not to hold the bill hostage to an attempt to force Daschle to schedule floor debate on the energy bill.

After a cloture vote of 100-0 to limit debate, Inhofe offered a sense of the Senate amendment calling on the Senate to take up an energy bill before the end of the first session of the 107th Congress. On a motion by Majority Whip Harry Reid (D-Nev.), the amendment was ruled non-germane. Reid promised that Daschle would bring an energy bill up before the end of the session, but Inhofe said that it was just more talk, as has been the case since the 1980s.

## Experts Admit: They Don't Know How To Stop Terrorism

On Sept. 26, the newly formed House Intelligence Subcommittee on Terrorism and Homeland Security held its first hearing, as Subcommittee Chairman Saxby Chambliss (R-Ga.) put it, "not just to continue to raise the profile of the issue of terrorism, but also to talk about what the real threats are." Witnesses included Virginia Gov. James Gilmore (R), who is chairman of a Congressionally created advisory

panel on U.S. preparedness to respond to terrorism; former Rep. Lee Hamilton (D-Ind.), who was a member of the U.S. Commission on National Security in the 21st Century; former Ambassador-at-Large for Terrorism Paul Bremer, who is chairman of the National Commission on Terrorism; former Deputy Secretary of Defense John Hamre, now president of the Center for Strategic and International Studies; and Dr. Bruce Hoffman, of the RAND Corp.

Rep. Ray LaHood (R-Ill.) opened up the most basic issue when he asked witnesses, "If we implemented all the recommendations" of the commissions represented at the table, "could that have prevented what happened on Sept. 11?" Hamilton called the question "highly speculative," and added that "the chances would be much greater to have prevented that kind of an incident if the Federal government was properly organized and coordinated to effectively deal with the threat of terrorism." Both Hamre and Gilmore noted that the attacks occurred with "zero prior warning." Gilmore added, "It is fruitless to try to predict any particular type of method in the absence of intelligence organization."

More interesting were the comments of Bremer and Huffman. Bremer said, "I can't honestly say what the impact would have been if our recommendations would have been followed. . . . It comes back basically to good intelligence," but "there is no way to do an analysis based on vulnerabilities in a free society." Huffman said, "I don't think all the recommendations would have made a difference. I think that what happened . . . was such a seismic change and really showed the terrorists to be of a very different order than we appreciated."

---

## Editorial

### *It's What They Haven't Told You*

Of the American media's performance since the events of Sept. 11, 2001, it may best be said: "What they don't tell you, may kill you."

From the moment the hijacked planes crashed into the World Trade Center and the Pentagon, the U.S. major media have been waging a 24 hour-a-day campaign to "out-Goebbels Goebbels," a non-stop barrage of disinformation, aimed at literally brainwashing the majority of Americans—including policymakers—into accepting the preposterous conclusion that "Osama bin Laden" masterminded the hideous irregular warfare attack of Sept. 11, the sophisticated financial warfare on international markets which preceded and followed it, and so forth.

From the first hours that morning, Lyndon LaRouche has warned that the bin Laden organization clearly lacked the capacity, alone, to conduct such a sophisticated, precision attack against American targets. In America, the media have censored these warnings, as they censored LaRouche's warnings, during the 2000 Presidential campaign, of the coming, now undeniable economic collapse.

During a live interview on K-TALK radio in Salt Lake City the morning of Sept. 11, as the first word came of the attacks in New York and Washington, LaRouche warned: "The first suspicion that's going to be on this is Osama bin Laden. That name is going to come up prominently."

Asked whether there was reason to doubt the bin Laden authorship, LaRouche replied, "Osama bin Laden is not an independent force." He detailed how Zbigniew Brzezinski and others launched the "Afghanistan war on the border of the Soviet territory" in the late 1970s, and "recruited a lot of Islamic people to fight Communism and defend Holy Islam. . . . Osama bin Laden was one of the big funding agents of this." LaRouche warned: "So now you can blame Osama bin Laden. At some point, you go in and kill him, and you say the problem was solved. But you never considered who sent, who created Osama bin Laden, and who protected him, and deployed his forces and name for these purposes."

More than three weeks after LaRouche issued this prescient warning, the entire American media remain in lock-step, behind this Goebbels-esque "Big Lie." Hundreds of thousands of words of print, and weeks worth of TV and radio coverage, have focussed on minute details about bin Laden and his al-Qaeda organization, but nowhere has the issue of the extraordinary sophistication and insider knowledge, required to have conducted the Sept. 11 attacks and surrounding events, been raised. To publicly raise such questions would be to immediately shoot down the "bin Laden did it" mantra.

In all successful propaganda/brainwashing campaigns, the secret is to lure the victim in with a stream of apparently "accurate details"—even though the "accurate details" periodically change!—that distract his or her attention from the larger questions, the questions that must be asked in order to conduct a successful truth-seeking effort. The American media have played the game of distraction-bombardment with precision, since Sept. 11.

In stark contrast to these media psy-ops, LaRouche—in many interviews, mostly with radio and TV stations *outside* the United States—warned that while assets of the Afghansi mujahideen may have been involved at the operational level, the overall operation had the character of a strategic covert irregular warfare attack, that required the involvement of contaminated elements of the U.S. military and security structures.

While scores of government officials and professional analysts around the world have privately concurred with LaRouche's assessment of an "enemy within," likely engaged in an ongoing coup d'état operation, the mass media have completely censored the very question itself, of such a deeper level of attack. But so long as Americans stay in a stupor of fixation on bin Laden and Afghanistan, the prospects of further acts of irregular warfare, challenging the very foundations of our Constitutional system, remain great. In this regard, CNN, Fox TV, the *Washington Post*, et al. are complicit, after the fact.



# SEE LAROUCHE ON CABLE TV

All programs are *The LaRouche Connection* unless otherwise noted. (\*) Call station for times.

## ALABAMA

- BIRMINGHAM—Ch. 4 Thursdays—11 pm
- UNIONTOWN—Ch. 2 Mon-Fri every 4 hrs. Sundays—Afternoons

## ALASKA

- ANCHORAGE—Ch. 44 Thursdays—10:30 pm
- JUNEAU—GCI Ch. 2 Wednesdays—10 pm

## ARIZONA

- PHOENIX—Ch. 98 Tuesdays—12 Noon
- TUCSON Cox Ch. 72/73/74 Thu.—12 Midnight

## ARKANSAS

- CABOT—Ch. 15 Daily—8 pm
- LITTLE ROCK Comcast Ch. 18 Tue.—1 am, or Sat-1 am, or 6 am

## CALIFORNIA

- ALAMO AT&T Ch. 1/99 2nd Fri.—9 pm
- BEVERLY HILLS Adelphia Ch. 37 Thursdays—4:30 pm
- BREA—Ch. 17\*
- BUENA PARK Adelphia Ch. 55 Tuesdays—6:30 pm
- CHATSWORTH T/W Ch. 27/34 Wed.—5:30 pm
- CLAYTON AT&T Ch. 25 2nd Fri.—9 pm
- CONCORD AT&T Ch. 25 2nd Fri.—9 pm
- COSTA MESA—Ch. 61 Mon—6 pm; Wed—3 pm Thursdays—2 pm
- CULVER CITY MediaOne Ch. 43 Wednesdays—7 pm
- DANVILLE AT&T Ch. 1/99 2nd Fri.—9 pm
- E. LOS ANGELES Adelphia Ch. 6 Mondays—2:30 pm
- FULLERTON Adelphia Ch. 65 Tuesdays—6:30 pm
- HOLLYWOOD MediaOne Ch. 43 Wednesdays—7 pm
- LAFAYETTE AT&T Ch. 1/99 2nd Fri.—9 pm
- LAVERNE—Ch. 3 Mondays—8 pm

- LONG BEACH Charter Ch. 65 Thursdays—1:30 pm
- MARINA DEL REY Adelphia Ch. 3 Thursdays—4:30 pm
- MEDIAONE Ch. 43 Wednesdays—7 pm
- MARTINEZ AT&T Ch. 1/99 2nd Fri.—9 pm
- MID-WILSHIRE MediaOne Ch. 43 Wednesdays—7 pm
- MODESTO AT&T Ch. 8 Mondays—2:30 pm
- MORAGA AT&T Ch. 1/99 2nd Fri.—9 pm
- ORINDA AT&T Ch. 1/99 2nd Fri.—9 pm
- PALOS VERDES Cox Ch. 33 Saturdays—3 pm
- PLACENTIA Adelphia Ch. 65 Tuesdays—6:30 pm
- PLEASANT HILL AT&T Ch. 1/99 2nd Fri.—9 pm
- SAN DIEGO—Ch. 16 Saturdays—10 pm
- SANTA ANA Adelphia Ch. 53 Tuesdays—6:30 pm
- SANTA MONICA Adelphia Ch. 77 Thursdays—4:30 pm
- TIGER VALLEY AT&T Ch. 3 2nd Fri.—9 pm
- TUJUNGA—Ch. 19 Fridays—5 pm
- VENICE—Ch. 43 Wednesdays—7 pm
- WALNUT CREEK AT&T Ch. 6 2nd Fri.—9 pm
- W. HOLLYWOOD Adelphia Ch. 3 Thursdays—4:30 pm

## COLORADO

- DENVER—Ch. 57 Saturdays—1 pm
- ## CONNECTICUT
- CHESTER—Ch. 15 Wednesdays—10:30 pm
  - GROTON—Ch. 12 Mondays—10 pm
  - MANCHESTER—Ch. 15 Mondays—10 pm
  - MIDDLETOWN—Ch. 3 Thursdays—5 pm
  - NEW HAVEN—Ch. 28 Sundays—10 pm

- NEWTOWN/NEW MIL. Charter Ch. 21 Mondays—9:30 pm Thursdays—11:30 am

## DIST. OF COLUMBIA

- WASHINGTON—Ch. 5 Alt. Sundays—3:30 pm

## IDAHO

- MOSCOW—Ch. 11 Mondays—7 pm

## ILLINOIS

- CHICAGO—Ch. 19 Wed, 10/24—6 pm Mon, 10/29—11:30 pm
- QUAD CITIES AT&T Ch. 6 Mondays—11 pm
- PEORIA COUNTY AT&T Ch. 22 Sundays—7:30 pm
- SPRINGFIELD—Ch. 4 Wednesdays—5:30 pm

## INDIANA

- DELAWARE COUNTY Adelphia Ch. 42 Mondays—11 pm

## IOWA

- QUAD CITIES AT&T Ch. 75 Mondays—11 pm

## KENTUCKY

- LATONIA—Ch. 21 Mon.-8 pm; Sat.-6 pm
- LOUISVILLE—Ch. 98 Fridays—2 pm

## LOUISIANA

- ORLEANS PARISH Cox Ch. 78 Tue., Thu., Sat. 4:30 am & 4:30 pm

## MARYLAND

- A. ARUNDEL—Ch. 20 Fri. & Sat.—11 pm
- BALTIMORE—Ch. 5 Wed.: 4 pm, 8 pm
- MONTGOMERY—Ch. 19/49 Fridays—7 pm
- P.G. COUNTY—Ch. 15 Mondays—10:30 pm
- W. HOWARD COUNTY MidAtlantic Ch. 6 Monday thru Sunday—1:30 am, 11:30 am, 4 pm, 8:30 pm

## MASSACHUSETTS

- AMHERST—Ch. 10\*
- BOSTON—BNN Ch. 3 Thursdays—3 pm
- WORCESTER—Ch. 13 Wednesdays—6 pm

## MICHIGAN

- BATTLE CREEK ATT Ch. 11 Mondays—4 pm

- CANTON TOWNSHIP MediaOne Ch. 18 Mondays—6 pm
- DEARBORN HEIGHTS MediaOne Ch. 18 Mondays—6 pm
- GRAND RAPIDS GRTV Ch. 25 Fridays—1:30 pm
- KALAMAZOO Cablevision Thu-11 pm (Ch. 31) Sat-9:30 pm (Ch. 33)
- MT. PLEASANT Charter Ch. 3 Tuesdays—5:30 pm Wednesdays—7 am
- PLYMOUTH—Ch. 18 Mondays—6 pm

## MINNESOTA

- ANOKA—Ch. 15 Thu.—11 am, 5 pm, 12 Midnight
- COLD SPRING U.S. Cable Ch. 3 Nightly after PSAs
- COLUMBIA HTS. MediaOne Ch. 15 Wednesdays—8 pm
- EAGAN/BURNSVILLE ATT Ch. 14, 57, 96 Tuesdays—5:30 pm Saturdays—9 pm Sundays—10 pm
- FRIDLEY Time Warner Ch. 5 Fridays—7 pm Saturdays—8:30 pm
- MINNEAP.—Ch. 32 Wednesdays—8:30 pm
- NEW ULM—Ch. 12 Thursdays—5 pm
- PROCTOR/HERMANTOWN—Ch. 12 Tue. btw. 5 pm - 1 am
- ROSEVILLE AT&T Ch. 14 Tue.—5 pm & 11 pm Wed.—5 am & 11 am
- ST. CROIX VALLEY Valley Access Ch. 14 Thursdays—4 & 10 pm Fridays—8 am
- ST. LOUIS PARK—Ch. 33 Friday through Monday 3 pm, 11 pm, 7 am
- ST. PAUL (city) SPIN Ch. 33 Saturdays—10 pm
- ST. PAUL (NE burbs)\* Suburban Community Ch. 15
- ST. PAUL (S&W burbs) AT&T Ch. 15 Tue & Fri—8 pm

## MISSOURI

- ST. LOUIS—Ch. 22 Wed.-5 pm; Thu.-Noon

## NEBRASKA

- LINCOLN Time Warner Channels 80 & 99 *Citizen Watchdog* Tue.—6 & 7 pm Wed.—8 & 10 pm

## NEVADA

- CARSON CITY—Ch. 10 Sun-2:30 pm; Wed-7 pm Saturdays—3 pm

## NEW HAMPSHIRE

- CLAREMONT AT&T Ch. 8\*

## NEW JERSEY

- MONTVALE/MAHWAH Time Warner Ch. 27 Wednesdays—4 pm

## NEW MEXICO

- ALBUQUERQUE Jones Ch. 27 Thursdays—4 pm
- LOS ALAMOS Adelphia Ch. 8 Sundays—7 pm Mondays—9 pm
- TAOOS Adelphia Ch. 2 Mondays—7 pm

## NEW YORK

- AMSTERDAM Time Warner Ch. 16 Thursdays—4:30 pm
- BROOKHAVEN (E. Suffolk) Cablevision Ch. 1/99 Wednesdays—9:30 pm
- BROOKLYN—BCAT Time Warner Ch. 35 Cablevision Ch. 68 Sundays—9 am
- BUFFALO Adelphia Ch. 18 Tuesdays—7 pm
- HORSEHEADS—Ch. 1 Mon, Fri.—4:30 pm
- HUDSON VALLEY Cablevision Ch. 62/90 Fridays—5 pm
- ILION—T/W Ch. 10 Saturdays—12:30 pm
- IRONDEQUOIT—Ch. 15 Mondays—7 pm Thu.—9:30 am & 7 pm
- JOHNSTOWN—Ch. 7 Tuesdays—4 pm
- MANHATTAN—MNN T/W Ch. 34; RCN Ch. 109 Alt. Sundays—9 am
- NASSAU—Ch. 71 Fridays—4 pm
- NIAGARA FALLS Adelphia Ch. 24 Thursdays—10:30 pm
- ONEIDA—T/W Ch. 10 Thursdays—10 pm
- PENFIELD—Ch. 12 Penfield Community TV\*

- POUGHKEEPSIE—Ch. 28 1st, 2nd Fridays—4 pm
- QUEENSBURY—Ch. 71 Thursdays—7 pm
- RIVERHEAD—Ch. 27 Thursdays—12 Midnight
- ROCHESTER—Ch. 15 Fri-11 pm; Sun-11 am
- ROCKLAND—Ch. 27 Wednesdays—4 pm
- SCHENECTADY—Ch. 16 Tuesdays—10 pm
- STATEN ISL.—Ch. 57 Thu.-11 pm; Sat.-8 am
- SUFFOLK—Ch. 25 2nd, 4th Mon.—10 pm
- SYRACUSE—T/W City: Ch. 3 Suburbs: Ch. 13 Fridays—8 pm
- TOMPKINS COUNTY Time Warner Sun.—9 pm (Ch. 78) Thu.—6 pm (Ch. 13) Sat.—9 pm (Ch. 78)
- TRI-LAKES Adelphia Ch. 2 Sun: 7 am, 1 pm, 8 pm
- UTICA—Ch. 25 Thursdays—6 pm
- WATERTOWN—Ch. 2 Tue: btwn. Noon-5 pm
- WEBSTER—Ch. 12 Wednesdays—8:30 pm
- WESTFIELD—Ch. 21 Mondays—12 Noon Wed., Sat.—10 am Sundays—11 am
- W. MONROE Time Warner Ch. 12 4th Wed.—1 am
- W. SENECA—Ch. 68 Thu.—10:30 pm

## NORTH CAROLINA

- MECKLENBURG Time Warner Ch. 18 Saturdays—12:30 pm

## OHIO

- AMHERST Amherst City Cable\*
- FRANKLIN COUNTY Ch. 21: Sun.—6 pm
- OBERLIN—Ch. 9 Tuesdays—7 pm
- REYNOLDSBURG Ch. 6: Sun.—6 pm

## OREGON

- CORVALLIS/ALB. AT&T Ch. 99 Tuesdays—1 pm
- PORTLAND AT&T Ch. 22 Tuesdays—6 pm Thursdays—3 pm
- SALEM—ATT Ch. 28 Tuesdays—12 Noon Thu.-8 pm; Sat.-10 am

- SILVERTON SCANV Ch. 10 Alt. Tuesdays 12 Noon-7 pm
- WASHINGTON—ATT Ch. 9: Tualatin Valley Ch. 23: Regional Area Ch. 33: Unincorp. Towns Mon-5 pm; Wed-10 am; Sundays—10 am

## RHODE ISLAND

- E. PROVIDENCE—Ch. 18 Tuesdays—6:30 pm
- STATEWIDE R.I. Interconnect\* Ch. 13 (Cox) Ch. 49 (Full)

## TEXAS

- EL PASO—Ch. 15 Wednesdays—5 pm
- HOUSTON Houston Media Source\* Sat, 10/13—2 pm Mon, 10/15—5 pm

## UTAH

- GLENWOOD, Etc. SCAT-TV Ch. 26, 29, 37, 38, 98 Sundays—about 9 pm

## VIRGINIA

- ARLINGTON ACT Ch. 33 Mondays—4:30 pm Tuesdays—9 am
- CHESTERFIELD Comcast Ch. 6 Tuesdays—5 pm
- FAIRFAX—Ch. 10 Tuesdays—12 Noon Thursdays—7 pm
- LOUDOUN Adelphia Ch. 23/24 Thursdays—7 pm
- ROANOKE—Ch. 9 Thursdays—2 pm

## WASHINGTON

- KING COUNTY AT&T Ch. 29/77 Sundays—6 pm
- SPOKANE—Ch. 14 Wednesdays—6 pm
- TRI-CITIES Falcon Ch. 13 Mon-noon; Wed-6 pm Thursdays—8:30 pm
- YAKIMA—Ch. 9 Sundays—4 pm

## WISCONSIN

- KENOSHA—Ch. 21 Mondays—1:30 pm
- MADISON—Ch. 4 Tue-2 pm; Wed-11 am
- MARATHON COUNTY Charter Ch. 10 Thursdays—9:30 pm; Fridays—12 Noon

## WYOMING

- GILLETTE—Ch. 36 Thursdays—5 pm

If you would like to get *The LaRouche Connection* on your local cable TV station, please call Charles Notley at 703-777-9451, Ext. 322. For more information, visit our Internet HomePage at <http://www.larouche.com>

## Executive Intelligence Review

U.S., Canada and Mexico only

1 year . . . . .	\$396
6 months . . . . .	\$225
3 months . . . . .	\$125

### Foreign Rates

1 year . . . . .	\$490
6 months . . . . .	\$265
3 months . . . . .	\$145

I would like to subscribe to *Executive Intelligence Review* for

1 year  6 months  3 months

I enclose \$\_\_\_\_\_ check or money order

Please charge my  MasterCard  Visa

Card No. \_\_\_\_\_ Exp. date \_\_\_\_\_

Signature \_\_\_\_\_

Name \_\_\_\_\_

Company \_\_\_\_\_

Phone ( \_\_\_\_\_ ) \_\_\_\_\_

Address \_\_\_\_\_

City \_\_\_\_\_ State \_\_\_\_\_ Zip \_\_\_\_\_

Make checks payable to **EIR News Service Inc.**  
P.O. Box 17390, Washington, D.C. 20041-0390.

# No to the 'Clash of Civilizations'!

The Anglo-American financier oligarchy is trying to unleash a "Clash of Civilizations," to block the vast potential for Eurasian development. Instead, the Western powers should join in the great project of the new millennium, the Eurasian Land-Bridge.

## The Eurasian Land-Bridge

The 'New Silk Road'—locomotive for  
worldwide economic development

including studies of:

- High-technology infrastructure development corridors
- China and Europe as Eurasia's development poles
- Crucial infrastructure projects in China
- The Eurasian Land-Bridge and development around the great ocean basins
- Financing an economic miracle: Hamiltonian credit generation
- The Eurasian Land-Bridge and the economic reconstruction of the United States



EIRNS  
Helga Zepp-LaRouche (right), known as "the Silk Road Lady," has played a major role in organizing worldwide support for the Eurasian Land-Bridge. She is shown here with Schiller Institute associates at Lianyungang Port in China, October 1998.

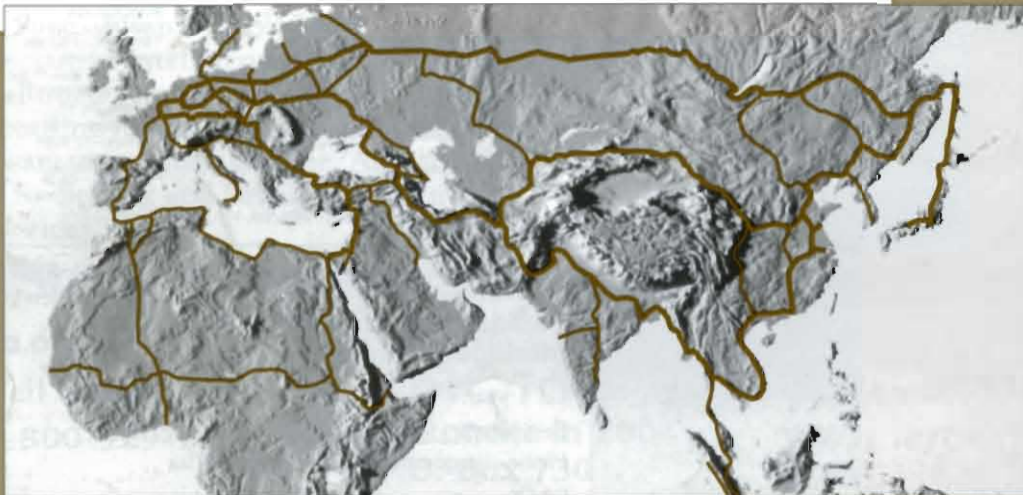

A special report  
from  
**Executive  
Intelligence  
Review**

260 pages **\$200**

**EIR News Service**

P.O. Box 17390 Washington, D.C. 20041-0390 Phone (toll-free): 1 888 EIR-3258